DESPIECE TECNICO

Hornos eléctricos
Fours électriques
Electric ovens
Elektro heissluftdämpfer
Forni elettrici
Fornos eletricos

Modelos:

COE-061

COE-101

VE-061

VE-101

VPE-061

VPE-101



PLATON SERVICE

8 (800) 500-34-47

www.platonservice.com

Julio 2009 July

Revisado Octubre 2012 / Revised October 2012



FAGOR INDUSTRIAL

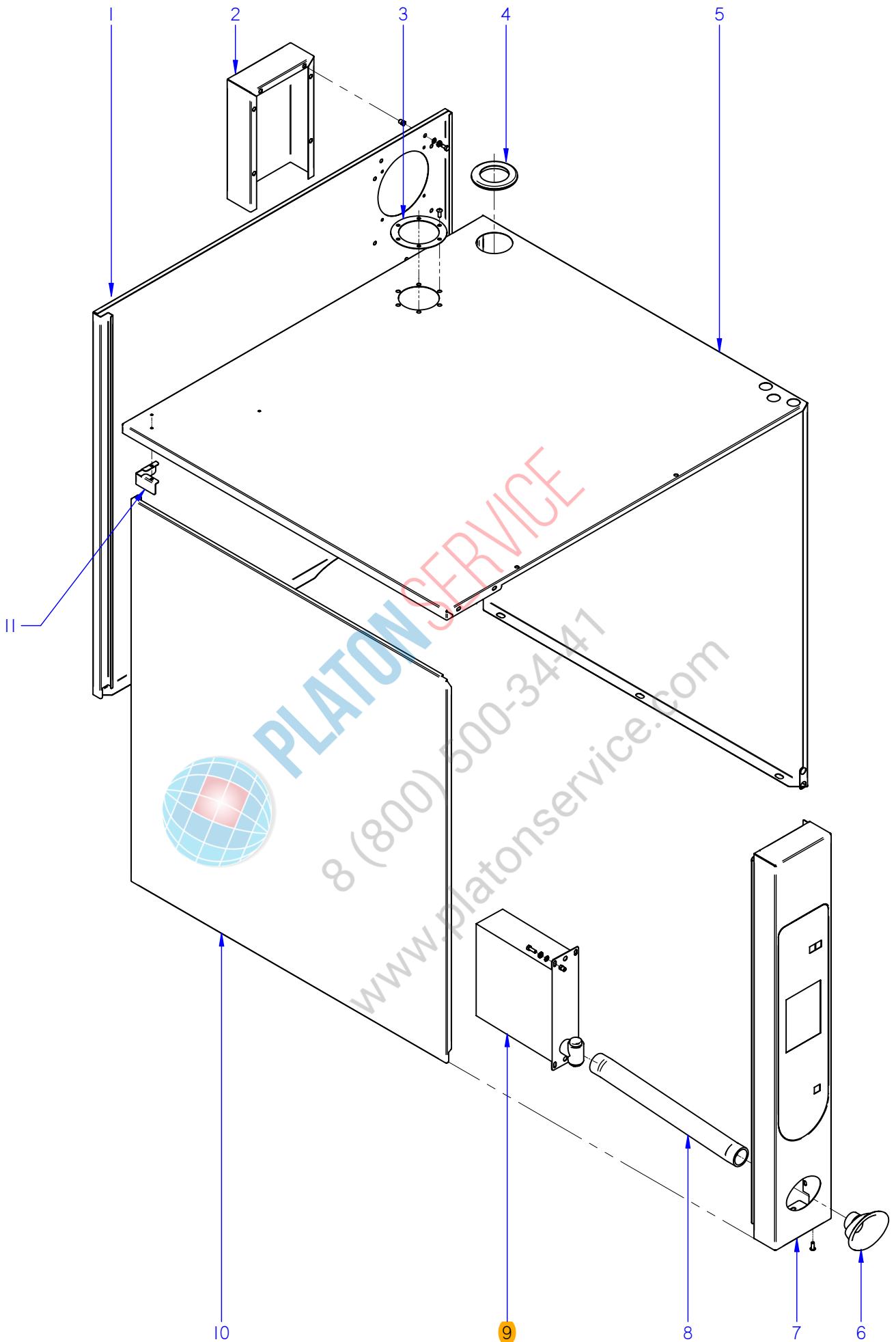

ITEM MARCADO EN COLOR = REPUESTO RECOMENDADO
 COLOURED ITEM = RECOMMENDED SPARE PART

N plano	Firma	Fecha	Aparato	MUEBLE	Lamina	Fagor Industrial S.Coop. FAGOR
C-2405	<i>(Signature)</i>	2009-07	HORNOS COE; VE; VPE 061 / 101		1	Oñate

MOD.		HORNOS / OVEN		ZONA	MUEBLE / UNIT						PLANO	C-2405
ITEM	CODIGO	DENOMINACION	TEXTO	COE-061	COE-101	VE-061	VE-101	VPE-061	VPE-101		NOTAS	
1	T902802000	PANEL POST EXTERIOR 6-11 EL	REAR EXTERIOR PANEL 6-11 E	1	-	1	-	1	-			
1	T812804000	PANEL POST EXTERIOR 10-11 EL	REAR EXTERIOR PANEL 10-11 E	-	1	-	1	-	1			
2	T812806500	CHAPA SEPARACION IPX5	SEPARATION PLATE IPX5	1	1	1	1	1	1			
S/Nº	T812811000	JUNTA IPX5	SEAL IPX5	1	1	1	1	1	1			
3	T325057000	JUNTA BASE CHIMENEA	FLUEPIPE BASE SEAL	1	1	1	1	1	1			
4	R662813000	PASAMUROS CHIMENEA 101003361	FEED THROUGH FLUE PIPE 1010	1	1	1	1	1	1			
5	T902801000	CUERPO EXTERIOR 6/11 ELECT.	EXTERIOR BODY 6/11 ELECT.	1	-	1	-	1	-		ELIMINADO 01.03.11	
5	T902801500	CUERPO EXTERIOR 061 E	EXTERIOR BODY 061 E	1	-	1	-	1	-		INTRODUCIDO 01.03.11	
5	T812802000	CUERPO EXTERIOR 10/11 ELECT.	EXTERIOR BODY 10/11 ELECT.	-	1	-	1	-	1		ELIMINADO 01.03.11	
5	T812802500	CUERPO EXTERIOR 101 E	EXTERIOR BODY 101 E	-	1	-	1	-	1		INTRODUCIDO 01.03.11	
6	T922801000	EMBELLECEDOR DUCHA	SHOWER TRIM	-	-	1	1	1	1			
7	T902808000	PANEL PORTAMANDO 6-11 HEI	CONTROL PANEL 6-11 HEI	1	-	-	-	-	-			
7	T802802000	PANEL PORTAMANDO 10-11 HEI	CONTROL PANEL 10-11 HEI	-	1	-	-	-	-			
7	T912804000	PANEL PORTAMANDO 6-11 HEM	CONTROL PANEL 6-11 HEM	-	-	1	-	-	-			
7	T812808000	PANEL PORTAMANDO 10-11 HEM	CONTROL PANEL 10-11 HEM	-	-	-	1	-	-			
7	T922804000	PANEL PORTAMANDO 6-11 HEP	CONTROL PANEL 6-11 HEP	-	-	-	-	1	-		ELIMINADO 15.06.10	
7	T922806000	PANEL PORTAMANDO VPE-061	CONTROL PANEL VPE-061	-	-	-	-	1	-		INTRODUCIDO 15.06.10	
7	T822803000	PANEL PORTAMANDO 10-11 HEP	CONTROL PANEL 10-11 HEP	-	-	-	-	-	1		ELIMINADO 15.06.10	
7	T822814000	PANEL PORTAMANDO VPE-101	CONTROL PANEL VPE-101	-	-	-	-	-	1		INTRODUCIDO 15.06.10	
S/Nº	T902807000	JUNTA PORTAMANDOS VERT 6/11	CONTROL HOLDER SEAL VERT 6/11	1	-	1	-	1	-			
S/Nº	T812809000	JUNTA PORTAMANDOS VERT 10/11	CONTROL HOLDER SEAL VERT 10/11	-	1	-	1	-	1			
S/Nº	T812810000	JUNTA PORTAMANDOS HORZ 10/11	CONTROL HOLDER SEAL HORZ 10/11	1	1	1	1	1	1			
8	3714100000	TUBO SILICONA Ø 38*31	SILICON PIPE Ø 38*31	-	-	1	1	1	1			
9	T452809000	DUCHA	SHOWER	-	-	1	1	1	1			
S/Nº	T452834000	MANGO DUCHA	SHOWER HANDLE	-	-	1	1	1	1		INTRODUCIDO 31.05.10	
	Q232030000	ARANDELA A5	FLAT WASHER A.5	-	-	4	4	4	4			
	Q242030000	ARANDELA ABANICO A5 A.304	FAN SHAPED WASHER A.5	-	-	4	4	4	4			
	Q012031000	TORNILLO EXAGONAL M5x10 A304	HEXAGONAL SCREW M.5x10	-	-	4	4	4	4			

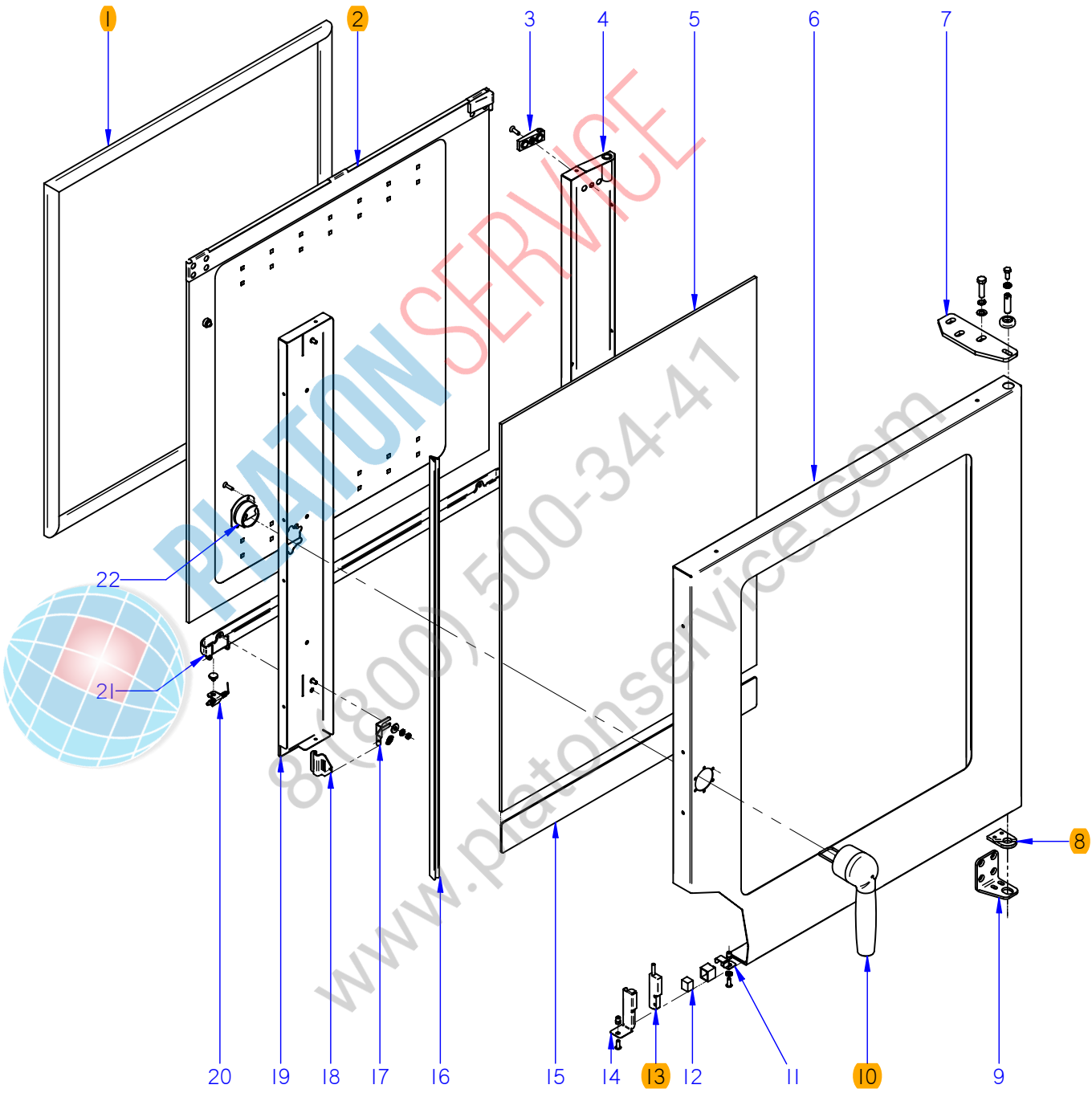

ITEM MARCADO EN COLOR = REPUESTO RECOMENDADO
 COLOURED ITEM = RECOMMENDED SPARE PART

N plano C-2406	Firma <i>(Signature)</i>	Fecha 2009-07	Aparato HORNOS COE; VE; VPE 061 / 101	PUERTA	Lamina 2	Fagor Industrial S. Coop. FAGOR Omate
-------------------	-----------------------------	------------------	--	--------	-------------	---

MOD.		HORNOS / OVEN		ZONA	PUERTA / DOOR						PLANO	C-2406
ITEM	CODIGO	DENOMINACION	TEXTO	COE-061	COE-101	VE-061	VE-101	VPE-061	VPE-101		NOTAS	
	1100003139	KIT PUERTA 6/11 COMPL.	DOOR 6/11 KIT	1	-	1	-	1	-			
	1100003141	KIT PUERTA 10/11 COMPL.	DOOR 10/11 KIT	-	1	-	1	-	1			
1	R660503000	JUNTA DE PUERTA 6/11	DOOR JOINT 6/11	1	-	1	-	1	-			
1	R670500000	JUNTA DE PUERTA 10/11	DOOR JOINT 10/11	-	1	-	1	-	1			
S/Nº	R660526000	FIJACION JUNTA DE PUERTA 6/11	DOOR SEAL FASTENING 6/11	1	-	1	-	1	-			
S/Nº	R670513000	FIJACION JUNTA DE PUERTA 10/11	DOOR SEAL FASTENING 10/11	1	-	1	-	1	-			
	Q032021000	TORNILLO ALOMADO M4X10	CURVED SCREW M.4x10	24	28	24	28	24	28			
2	1100003130	KIT CRISTAL INTER. 6/11	6/11 INNER GLASS KIT	1	-	1	-	1	-			
2	1100003132	KIT CRISTAL INTER. 10/11	10/11 INNER GLASS KIT	-	1	-	1	-	1			
3	R670615000	BASE DE BISAGRA	HINGE BASE	2	2	2	2	2	2			
	Q042032000	TORNILLO AVELLANADO M5X15	COUNTERSUNK SCREW M.5x15	2	2	2	2	2	2			
4	T900505000	CONTRAPUERTA BISAGRA 6/11	INNER DOOR HINGE 6/11	1	-	1	-	1	-			
4	T840504000	CONTRAPUERTA BISAGRA 10/11	INNER DOOR HINGE 10/11	-	1	-	1	-	1			
	Q221341000	REMACHE EXAGONAL M.4	HEXAGONAL RIVET M.4	1	1	1	1	1	1			
	Q222011000	REMACHE EXAGONAL M.5	HEXAGONAL RIVET M.5	2	2	2	2	2	2			
5	R660610000	CRISTAL EXTERIOR 6/11	EXTERNAL GLASS 6/11	1	-	1	-	1	-			
5	R670627000	CRISTAL EXTERIOR 10/11	EXTERNAL GLASS 10/11	-	1	-	1	-	1			
	R670617000	TOPE CRISTAL INTERIOR	INTERIOR GLASS BUFFER	3	4	3	4	3	4			
6	T900501500	PANEL PUERTA 6/11	DOOR PANEL 6/11	1	-	1	-	1	-			
6	T840501500	PANEL PUERTA 10/11	DOOR PANEL 10/11	-	1	-	1	-	1			
S/Nº	T900508000	CALZO PUERTA	DOOR WEDGE	1	1	1	1	1	1			
	Q242040000	ARANDELA ABANICO A6 A.304	FAN SHAPED WASHER A.6	2	2	2	2	2	2			
	Q012041000	TORNILLO EXAGONAL M6x10	HEXAGONAL BOLT M6x10	2	2	2	2	2	2			
	Q062040000	TORNILLO AVELLANADO M6x16	COUNTERSUNK SCREW M6x16	4	4	4	4	4	4			
7	T130500000	BISAGRA SUPERIOR	UPPER HINGE	1	1	1	1	1	1			
	Q302025000	ARANDELA 8,4X20X1.5	FLAT WASHER 8,4X20X1.5	3	3	3	3	3	3			
	Q261050000	ARANDELA MUELLE A8	SPRING WASHER A8	3	3	3	3	3	3			
	Q012055000	TORNILLO EXAGONAL M8X30	HEXAGONAL BOLT M8X30	3	3	3	3	3	3			
S/Nº	R660534000	EJE SUPERIOR	UPPER SHAFT	1	1	1	1	1	1			
	R662807000	ARANDELA AMARRE	DOOR ANCHORING WASHER	1	1	1	1	1	1			
	Z850519000	RESORTE 06329	SPRING 06329	1	1	1	1	1	1			

MOD.		HORNOS / OVEN		ZONA		PUERTA / DOOR				PLANO		C-2406
ITEM	CODIGO	DENOMINACION	TEXTO	COE-061	COE-101	VE-061	VE-101	VPE-061	VPE-101		NOTAS	
8	R660549000	GUIA EJE INFERIOR FUNDIDO	LOWER SHAFT GUIDE	1	1	1	1	1	1			
	Q062040000	TORNILLO AVELLANADO M6X16	COUNTERSUNK SCREW M.6x16	4	4	4	4	4	4			
9	R660551500	BISAGRA INFERIOR PLEGADA	LOWER FOLDER HINGE	1	1	1	1	1	1		ELIMINADO 01.12.09	
9	R660551000	BISAGRA INFERIOR PLEGADA	LOWER FOLDER HINGE	1	1	1	1	1	1		INTRODUCIDO 01.12.09	
10	T900506000	MANILLA COMPLETA	HANDLE	1	1	1	1	1	1			
	Q042022000	TORNILLO AVELLANADO M4X15	COUNTERSUNK SCREW M.4x15	3	3	3	3	3	3			
11	T130513000	SOPORTE IMAN	MAGNET HOLDER	1	1	1	1	1	1			
	Q222011000	REMACHE EXAGONAL M.5	HEXAGONAL RIVET M.5	1	1	1	1	1	1			
	Q242030000	ARANDELA ABANICO A5 A.304	FAN SHAPED WASHER A.5	1	1	1	1	1	1			
	Q152004000	TORNIL. APLASTADO M5X13 A 304	FLAT SCREW M.5x13	1	1	1	1	1	1			
12	Z200506000	IMAN	MAGNET	1	1	1	1	1	1			
S/Nº	Z200507000	PROTECTOR IMAN	MAGNET PROTECTOR	1	1	1	1	1	1			
13	Z100522000	INTERRUPTOR MAGNETICO AC	MAGNETIC SWITCH AC	1	1	1	1	1	1			
14	T302819000	SOPORTE MICRO PUERTA	DOOR MICRO SWITCH	1	1	1	1	1	1			
	Q152004000	TORNIL. APLASTADO M5X13 A 304	FLAT SCREW M.5x13	1	1	1	1	1	1			
15	T800501000	TOPE CRISTAL EXTERIOR 10/11	EXTERNAL GLASS STOP	1	1	1	1	1	1			
16	3715200000	JUNTA CRISTAL	WINDOW SEAL	2	2	2	2	2	2			
17	R670612000	BASE DE PESTILLO	LATCH BASE	2	2	2	2	2	2			
18	R670613000	PESTILLO	LATCH	2	2	2	2	2	2			
	R660605000	MUELLE TENSOR	LATCH TENSOR SPRING	2	2	2	2	2	2			
	Q302022000	ARANDELA 16X6X1.2 A.304	FLAT WASHER 16x6x1,2	2	2	2	2	2	2			
	Q242030000	ARANDELA ABANICO A5 A.304	FAN SHAPED WASHER A.5	2	2	2	2	2	2			
	Q162030000	TUERCA EXAGONAL M5	HEXAGONAL NUT M.5	2	2	2	2	2	2			
	T900504000	CONTRAP MANILLA COMPL 6/11	COMPLETE HANDLE DOOR 6/11	1	-	1	-	1	-			
19	T840502000	CONTRAP MANILLA COMPL 10/11	COMPLETE HANDLE DOOR 10/11	-	1	-	1	-	1			
	Q221341000	REMACHE EXAGONAL M4	HEXAGONAL RIVET M.4	3	3	3	3	3	3			
20	T840508000	CIERRE RECOGEAGUAS	WATER COLLECTOR COVER	1	1	1	1	1	1			
	T300518000	TAPON CIERRE CANALETA	CAP CHANNEL COVER	1	1	1	1	1	1		ELIMINADO 01.03.11	
	T840510000	JUNTA CIERRE RECOGEAGUAS	JOINT WATER COLLECTOR COV	1	1	1	1	1	1		INTRODUCIDO 01.03.11	
	T840509000	MUELLE CIERRE RECOGEAGUAS	SPRING WATER COLLECTOR CO	1	1	1	1	1	1			

N plano
C-2407
Firma
Fecha
2009-07
Aparato
HORNO COE; VE; VPE 061 / 101
MUEBLE INTERIOR
Lamina
3
Fagor Industrial S. Coop. FAGOR
Omate

ITEM MARCADO EN COLOR = REPUESTO RECOMENDADO
COLOURED ITEM = RECOMMENDED SPARE PART

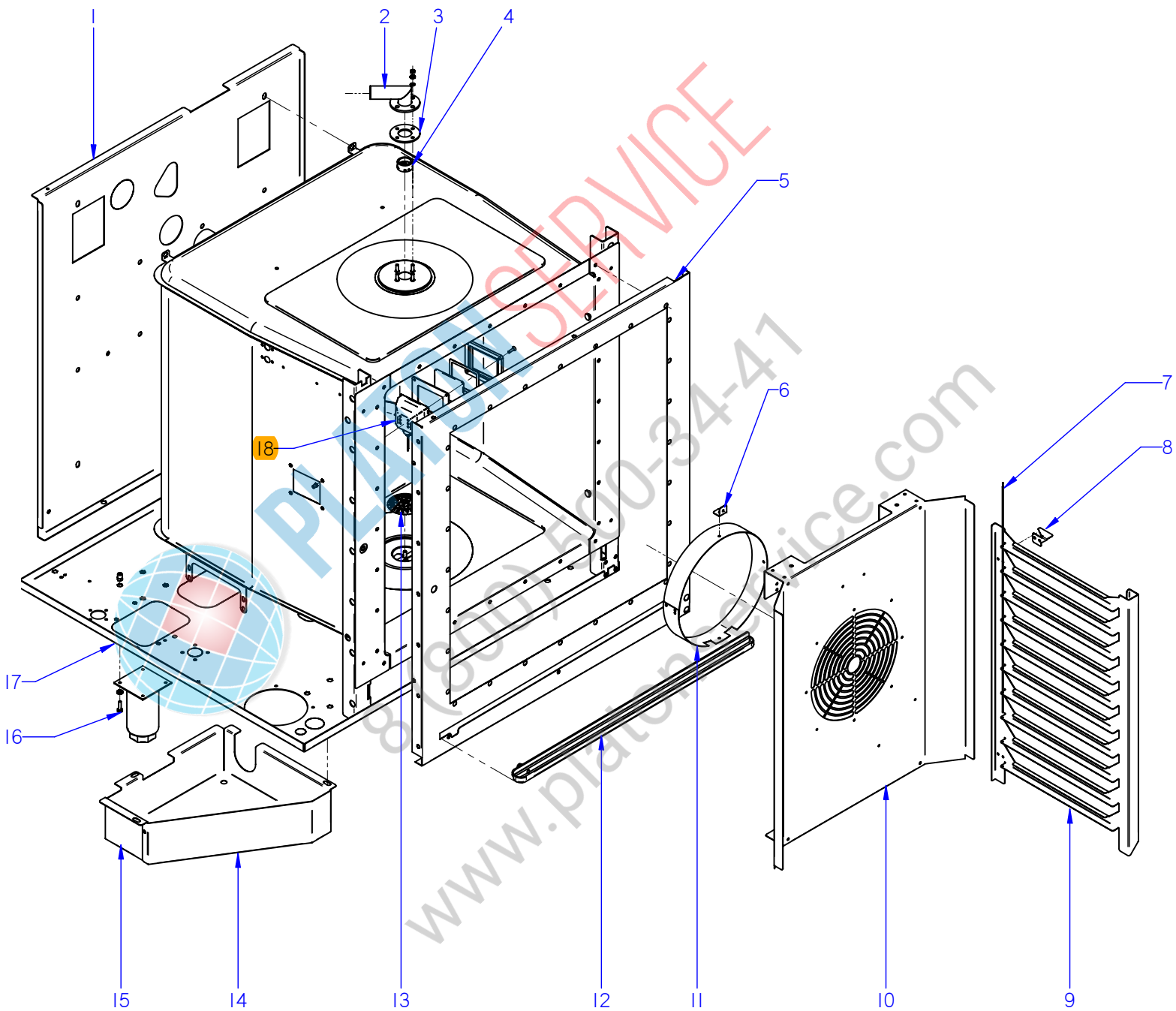

MOD.		HORNOS / OVEN		ZONA		MUEBLE INTERIOR / INTERIOR OVEN				PLANO		C-2407	
ITEM	CODIGO	DENOMINACION	TEXTO	COE-061	COE-101	VE-061	VE-101	VPE-061	VPE-101			NOTAS	
1	T912601000	SOPORTE AISLANTE POST 6-11E	REAR INSULATION SUPPORT	1	-	1	-	1	-				
1	T812611000	SOPORTE AISLANTE POST 10-11E	REAR INSULATION SUPPORT	-	1	-	1	-	1				
	Q221343000	REMACHE EXAGONAL M.6	HEXAGONAL RIVET M.6	3	3	3	3	3	3				
	Q221342000	REMACHE EXAGONAL M.5	HEXAGONAL RIVET M.5	3	3	3	3	3	3				
	Q232040000	ARANDELA A6	FLAT WASHER A.6	11	11	11	11	11	11				
	Q242040000	ARANDELA ABANICO A6 A.304	FAN SHAPED WASHER A.6	11	11	11	11	11	11				
	Q012042000	TORNILLO EXAGONAL M6x15	HEXAGONAL BOLT M6x15	11	11	11	11	11	11				
	Q242030000	ARANDELA ABANICO A5 A.304	FAN SHAPED WASHER A.5	4	4	4	4	4	4				
	Q012031000	TORNILLO EXAGONAL M5X10	HEXAGONAL BOLT M5X10	4	4	4	4	4	4				
2	T820702000	TUBO DIFUSOR LAVADO COMP.	COMPL. WASHING DISPENSER F	-	-	-	-	1	1			ELIMINADO 01.08.10	
	Q232030000	ARANDELA A5	FLAT WASHER A.5	-	-	-	-	4	4			ELIMINADO 01.08.10	
	Q242030000	ARANDELA ABANICO A5 A.304	FAN SHAPED WASHER A.5	-	-	-	-	4	4			ELIMINADO 01.08.10	
	Q162030000	TUERCA EXAGONAL M5	HEXAGONAL NUT M.5	-	-	-	-	4	4			ELIMINADO 01.08.10	
3	T330744000	CHAPA AMARRE TUBO LAVADO	WASHING PIPE FASTENING PLA	-	-	-	-	1	1			ELIMINADO 01.08.10	
4	T360712000	PUNTA DIFUSORA LAVADO	WASHING DISPENSER POINT	-	-	-	-	1	1				
5	T912801000	CHAPA FRONTAL 6-11	FRONT PLATE 6-11	1	-	1	-	1	-				
5	T812801000	PANEL FRONTAL 10-11	FRONT PANEL 10-11	-	1	-	1	-	1				
	Q221342000	REMACHE EXAGONAL M.5	HEXAGONAL RIVET M.5	11	11	11	11	11	11				
	Q232040000	ARANDELA A6	FLAT WASHER A.6	3	3	3	3	3	3				
	Q242040000	ARANDELA ABANICO A6 A.304	FAN SHAPED WASHER A.6	3	3	3	3	3	3				
	Q012042000	TORNILLO EXAGONAL M6x15	HEXAGONAL BOLT M6x15	3	3	3	3	3	3				
	Q222041000	REMACHE EXAGONAL M.4 INOX	HEXAGONAL RIVET M.4 INOX	3	3	3	3	3	3				
6	T302643000	FIJACIÓN SUPLEMENTO	FAN COVER SUPPLEMENT BIND	4	8	4	8	4	8				
	Q412002000	REMACHE AVINOX Ø4x10MM	TUBULAR RIVET 4x7,5	8	20	8	20	8	18				
7	R662693000	TOPE PORTABANDEJAS 6/11	TRAY HOLDER BUFFER 6/11	2	-	2	-	2	-				
7	R672692000	TOPE PORTABANDEJAS 10/11	TRAY HOLDER BUFFER 10/11	-	2	-	2	-	2				
8	R672691000	ESCUADRA SUJECCION 6-10/11	FASTENING BRACKET	4	4	4	4	4	4				
	Q412002000	REMACHE AVINOX Ø4x10MM	TUBULAR RIVET 4x7,5	8	8	8	8	8	8				

MOD.		HORNOS / OVEN		ZONA	MUEBLE INTERIOR / INTERIOR OVEN					PLANO	C-2407
ITEM	CODIGO	DENOMINACION	TEXTO	COE-061	COE-101	VE-061	VE-101	VPE-061	VPE-101		NOTAS
9	R692616000	GUIA DE BANDEJA DCHA.6/11	RIGHT TRAY GUIDE 6/11	1	-	1	-	1	-		
9	R672612000	GUIA DE BANDEJA DCHA.10/11	RIGHT TRAY GUIDE 10/11	-	1	-	1	-	1		
S/Nº	R692617000	GUIA DE BANDEJA IZDA.6/11	LEFT TRAY GUIDE 6/11	1	-	1	-	1	-		
S/Nº	R672613000	GUIA DE BANDEJA IZDA.10/11	LEFT TRAY GUIDE 10/11	-	1	-	1	-	1		
10	T902603000	CUBREVENTILADOR 6/11 ELECT.	FAN COVER 6/11 ELECT.	1	-	1	-	1	-		
10	T802605000	CUBREVENTILADOR 10/11 ELECT.	FAN COVER 10/11 ELECT.	-	1	-	1	-	1		
11	T132644000	2011G SUPL. CUBREVENTILADOR	2011G SUPPL. FAN COVER	1	-	1	-	1	-		ELIMINADO 01.12.09
11	T902609000	061 SUPL. CUBREVENTILADOR	061 SUPPL. FAN COVER	1	-	1	-	1	-		INTRODUCIDO 01.12.09
11	T132644000	2011G SUPL. CUBREVENTILADOR	2011G SUPPL. FAN COVER	-	1	-	1	-	1		
12	T842809000	RECOGEAGUAS PLAST 6-10/11	PLAST SPRING WATER COLLE.	1	1	1	1	1	1		
	Q242040000	ARANDELA ABANICO A6 A.304	FAN SHAPED WASHER A.6	3	3	3	3	3	3		
	Q032021000	TORNILLO ALOMADO M4x10	CURVED SCREW M.4x10	3	3	3	3	3	3		
13	T302695000	FILTRO DESAGÜE	DRAINAGE FILTER	1	1	1	1	1	1		ELIMINADO 14.09.10
13	T642657000	FILTRO DESAGÜE	DRAINAGE FILTER	1	1	1	1	1	1		INTRODUCIDO 14.09.10
14	T820706000	TAPA CAJA CUBRE SIST LAVADO	COVER WASHING SYSTEM BOX	-	-	-	-	1	1		ELIMINADO 01.03.11
14	T330752500	TAPA SISTEMA LAVADO	TOP WASHING SYSTEM	-	-	-	-	1	1		INTRODUCIDO 01.03.11
	Q152004000	TORNILLO APLAST. M5X13 A 304	FLAT SCREW M.5x13	-	-	-	-	2	2		
15	T820705000	CAJA CUBRE SISTEMA LAVADO	CLEANING SYSTEM BOX	-	-	-	-	1	1		ELIMINADO 01.03.11
15	T920701000	CAJA CUBRE BOMBA LAVADO	CLEANING PUMP BOX	-	-	-	-	1	1		INTRODUCIDO 01.03.11
	Q221342000	REMACHE EXAGONAL M.5	HEXAGONAL RIVET M.5	-	-	-	-	2	2		
	Q232030000	ARANDELA A5	FLAT WASHER A.5	-	-	-	-	3	3		
	Q242030000	ARANDELA ABANICO A5 A.304	FAN SHAPED WASHER A.5	-	-	-	-	3	3		
	Q012031000	TORNILLO EXAGONAL M5X10	HEXAGONAL BOLT M5X10	-	-	-	-	3	3		
16	X260151000	PATA REGULABLE	REGULABLE LEG	4	4	4	4	4	4		
	Q232040000	ARANDELA A6	FLAT WASHER A.6	16	16	16	16	16	16		
	Q242040000	ARANDELA ABANICO A6 A.304	FAN SHAPED WASHER A.6	16	16	16	16	16	16		
	Q012043000	TORNILLO EXAGONAL M6x20	HEXAGONAL BOLT M6x20	16	16	16	16	16	16		
17	T912802000	BASE HORNO 6/11 10/11	OVEN BASE 6/11 10/11	1	1	1	1	1	1		
	Q221343000	REMACHE EXAGONAL M.6	HEXAGONAL RIVET M.6	30	30	30	30	30	30		
	Q221342000	REMACHE EXAGONAL M.5	HEXAGONAL RIVET M.5	12	12	12	12	12	12		

N plano	Firma	Fecha	Aparato	TURERINA	Lamina	Fagor Industrial S. Coop. FAGOR
C-2408		2009-07	HORNOS COE; VE; VPE 061 / 101		4	Omate

ITEM MARCADO EN COLOR = REPUESTO RECOMENDADO
 COLOURED ITEM = RECOMMENDED SPARE PART

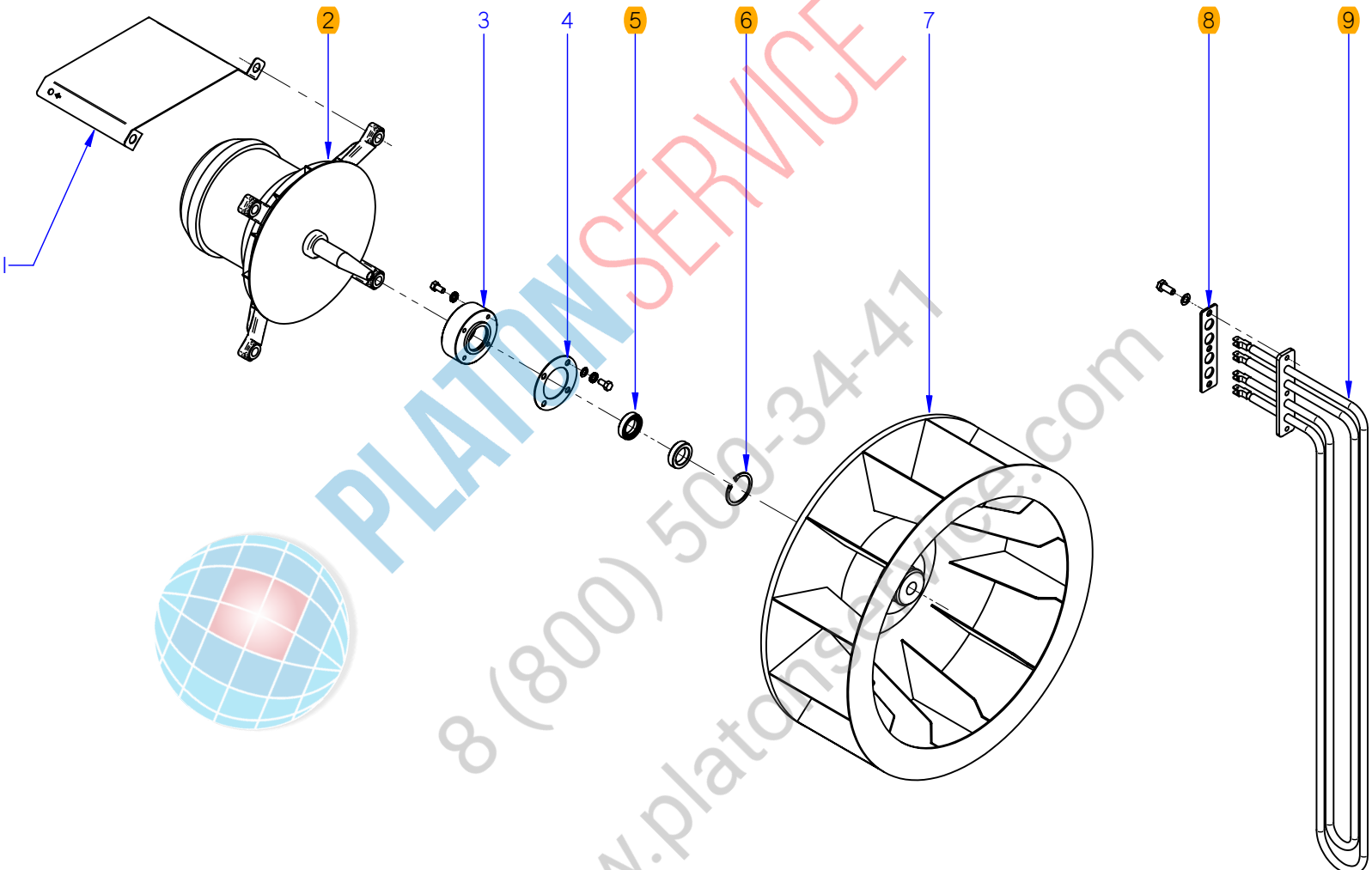

MOD.		HORNOS / OVEN		ZONA	TURBINA / TURBINE						PLANO	C-2408
ITEM	CODIGO	DENOMINACION	TEXTO	COE-061	COE-101	VE-061	VE-101	VPE-061	VPE-101		NOTAS	
1	T142635000	TEJADILLO MOTOR	MOTOR ROOF	1	1	1	1	1	1			
2	T303066000	MOTOR DOBLE GIRO 1VEL. 750W.	DOUBLE ROTATION MOTOR 1VE	1	-	1	-	1	-			
2	T303066000	MOTOR DOBLE GIRO 1VEL. 750W.	DOUBLE ROTATION MOTOR 1VE	-	1	-	1	-	1		ELIMINADO 31.03.10	
2	T323040000	MOTOR DOBLE GIRO 1VEL. 750W.	DOUBLE ROTATION MOTOR 1VE	-	1	-	1	-	1		INTRODUCIDO 31.03.10	
	Q232040000	ARANDELA A6	FLAT WASHER A.6	4	4	4	4	4	4			
	Q242040000	ARANDELA ABANICO A6 A.304	FAN SHAPED WASHER A.6	4	4	4	4	4	4			
	Q152039000	TORNILLO EXAGONAL M6X35	HEXAGONAL SCREW M6X35	4	4	4	4	4	4			
3	R662684000	CASQUILLO RETEN	SEAL BUSHING	1	1	1	1	1	1			
4	R662685000	JUNTA CASQUILLO RETEN	SEAL BUSHING GASKET	1	1	1	1	1	1			
	Q232030000	ARANDELA A5	FLAT WASHER A.5	4	4	4	4	4	4			
	Q242030000	ARANDELA ABANICO A5 A.304	FAN SHAPED WASHER A.5	4	4	4	4	4	4			
	Q012031000	TORNILLO EXAGONAL M5X10	HEXAGONAL SCREW M5X10	4	4	4	4	4	4			
5	R662627000	RETEN 17X28X7V	RETAINER 28x17x7	2	2	2	2	2	2			
6	Q302023000	ANILLO DE SEGURIDAD Ø 28X1.2	SAFETY RING 28x1,2	1	1	1	1	1	1			
7	T083005000	TURBINA ALAB. REC.Ø280x127	TURBINE ALAB. REC. 280x127	1	-	1	-	1	-			
7	T493017000	TURBINA RECTA Ø350X127 FIR	TURBINE RECTA Ø350X127 FIR	-	1	-	1	-	1		ELIMINADO 31.03.10	
7	R703050000	TURBINA RECTA Ø350X127 HANN.	TURBINE RECTA Ø350X127 HAN	-	1	-	1	-	1		INTRODUCIDO 31.03.10	
	R763010000	ARANDELA SEGURIDAD HANNING	HANNING SAFETY WASHER	1	1	1	1	1	1			
	Q012063000	TORNIL. EXAGONAL M10X20 A.304	HEXAGONAL SCREW M.10x20	1	1	1	1	1	1			
8	R693017000	JUNTA RESISTENCIAS 6-11	ELEMENT SEAL 6-11	6	-	6	-	6	-			
8	R673063000	JUNTA RESISTENCIAS 10-11	ELEMENT SEAL 10-11	-	6	-	6	-	6			
9	R663016000	RESISTENCIA CONVECCION 230V	ELEMENT 230V	6	-	6	-	6	-			
9	R673002000	RESISTENCIA CONVECCION	ELEMENT	-	6	-	6	-	6			
	Q232040000	ARANDELA A6	FLAT WASHER A.6	18	18	18	18	18	18			
	Q013042000	TORNILLO EXAGONAL M6x15	HEXAGONAL SCREW	18	18	18	18	18	18			

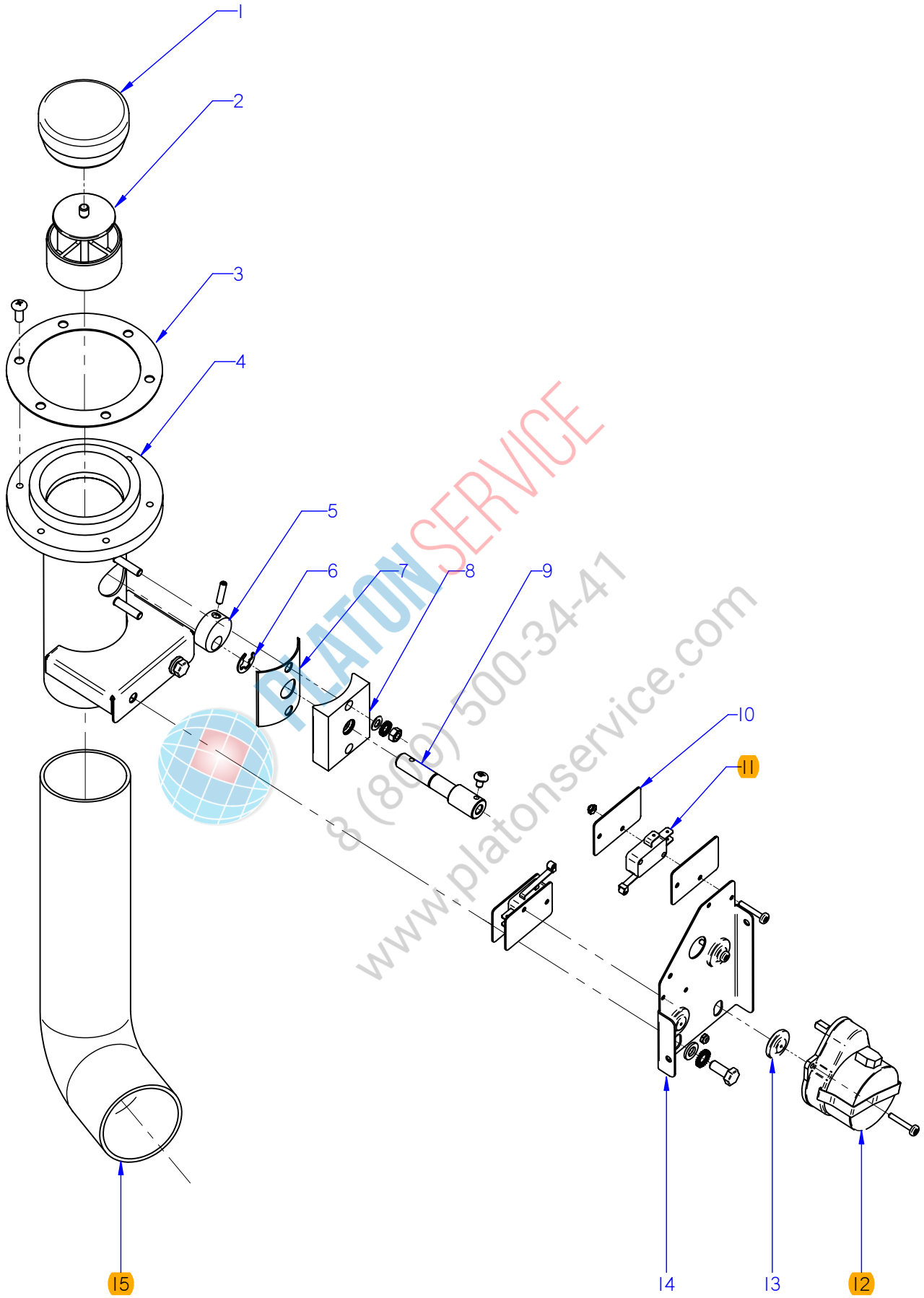

ITEM MARCADO EN COLOR = REPUESTO RECOMENDADO
 COLOURED ITEM = RECOMMENDED SPARE PART

N plano	Firma	Fecha	Aparato	CHIMENEA	Lamina	Fagor Industrial S.Coop. FAGOR
C-2409	<i>(Signature)</i>	2009-07	HORNOS COE; VE; VPE 061 /101	5	Oñate	

MOD.		HORNOS / OVEN		ZONA		CHIMENEA / FLUEPIPE				PLANO		C-2409	
ITEM	CODIGO	DENOMINACION	TEXTO	COE-061	COE-101	VE-061	VE-101	VPE-061	VPE-101			NOTAS	
1	T325055000	RETENCION DE VAPORES	CLOSE CHIMNEY	1	1	1	1	1	1				
2	T815014000	GUIA RETENCION VAPORES	STEAM RETAINER GUIDE	1	1	1	1	1	1				
3	T325057000	JUNTA BASE CHIMENEA	FLUEPIPE BASE SEAL	1	1	1	1	1	1				
	Q152004000	TORNIL. APLASTADO M5X13 A 304	FLAT SCREW M.5x13	6	6	6	6	6	6				
4	T915015000	CONJUNTO CHIMENEA 6/11	COMPLETE CHIMNEY 6/11	1	-	1	-	1	-				
4	T815006000	CONJUNTO CHIMENEA	COMPLETE CHIMNEY	-	1	-	1	-	1				
	Q221343000	REMACHE EXAGONAL M.6	HEXAGONAL RIVET M.6	2	2	2	2	2	2				
5	T325032000	LEVA EJE CHIMENEA	FLUEPIPE SHAFT CAM	1	1	1	1	1	1				
	Q132045000	VARILLA ROSCADA M4X16	THREADED ROD M4X16	1	1	1	1	1	1				
6	Q271006000	ARANDELA DE SEGURIDAD Ø8	SAFETY WASHER Ø8	1	1	1	1	1	1				
7	T325030000	JUNTA EJE CHIMENEA	FLUEPIPE SHAFT SEAL	1	1	1	1	1	1				
8	T325029000	GUIA EJE CHIMENEA	FLUEPIPE SHAFT GUIDE	1	1	1	1	1	1				
	Q232030000	ARANDELA A5	FLAT WASHER A.5	2	2	2	2	2	2				
	Q242030000	ARANDELA ABANICO A5 A.304	FAN SHAPED WASHER A.5	2	2	2	2	2	2				
	Q162030000	TUERCA EXAGONAL M5	HEXAGONAL NUT M.5	2	2	2	2	2	2				
9	T815010000	EJE CHIMENEA ELECTRICA	ELECTRIC FLUEPIPE SHAFT	1	1	1	1	1	1				
	Q151320000	TORNILLO ALOMADO M4X6 ZINC.	CURVED SCREW M4X6 ZINC.	1	1	1	1	1	1				
10	R010535000	PLACA SEPARADORA	SPACER PLATE	4	4	4	4	4	4				
	Q032013000	TORNILLO ALOMADO M3X20	CURVED SCREW M3X20	4	4	4	4	4	4				
	Q221350000	TUERCA AUTOBLOCANTE M3	SELF-LOCKING NUT M3	4	4	4	4	4	4				
11	R010534000	INTERRUPTOR PUERTA	DOOR SWITCH	2	2	2	2	2	2				
12	T323010000	MOTOR CHIMENEA	FLUEPIPE MOTOR	1	1	1	1	1	1				
13	Q308006000	ARANDELA DUBO Ø 4	WASHER DUBO Ø 4	3	3	3	3	3	3				
14	T815009000	ESCUA. AMARRE MOTOR CHIMEN.	FLUEPIPE MOTOR FASTENING B	1	1	1	1	1	1				
	Q232040000	ARANDELA A6	FLAT WASHER A.6	2	2	2	2	2	2				
	Q242040000	ARANDELA ABANICO A6 A.304	FAN SHAPED WASHER A.6	2	2	2	2	2	2				
	Q012042000	TORNILLO EXAGONAL M6X15 A304	HEXAGONAL SCREW M6X15	2	2	2	2	2	2				
15	T722608000	TUBO FLEXIBLE Ø53X360	FLEXIBLE TUBE Ø53X360	-	1	1	1	1	1				
	Q881307000	ABRAZADERA 40*60	CLAMP 40*60	-	2	2	2	2	2				

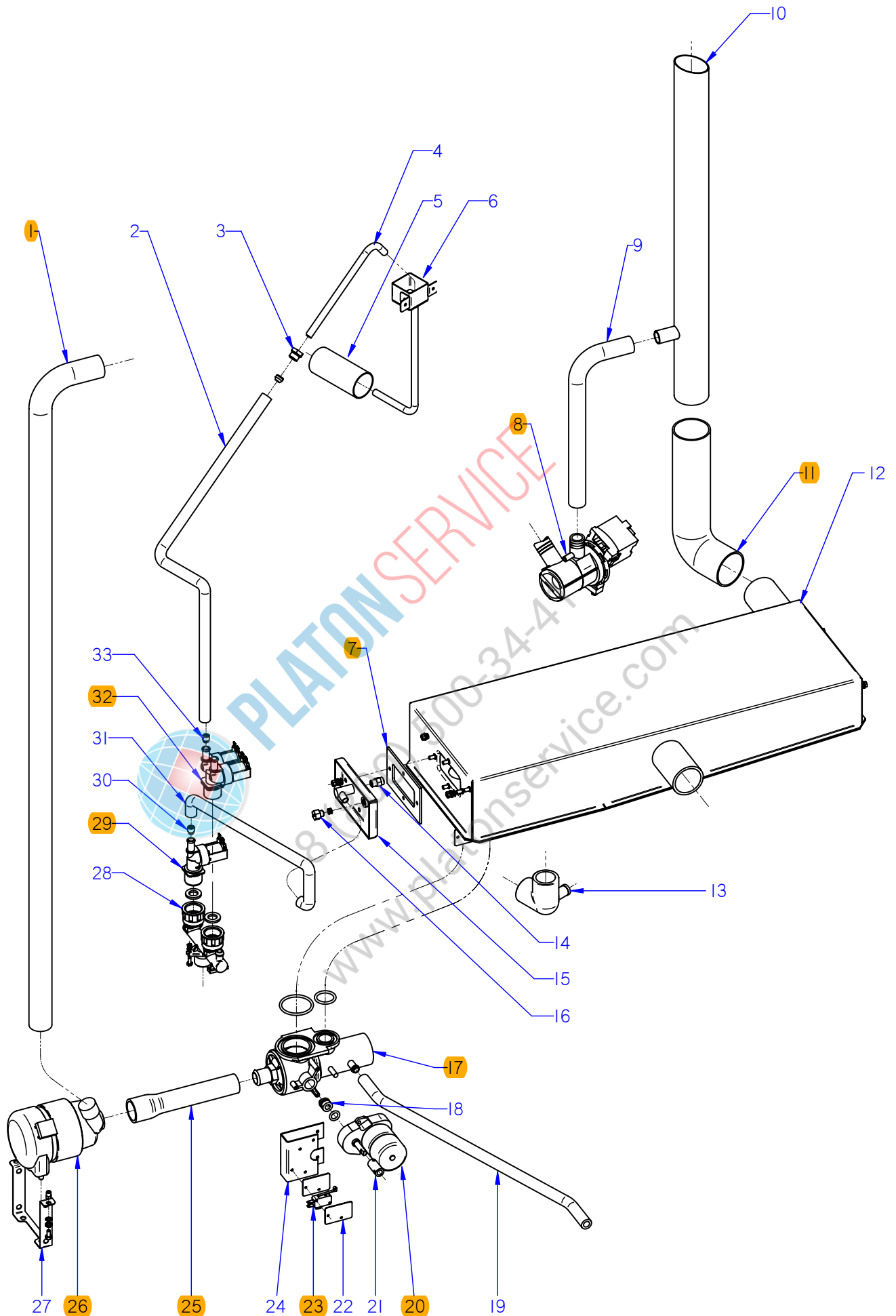

ITEM MARCADO EN COLOR = REPUESTO RECOMENDADO
 COLOURED ITEM = RECOMMENDED SPARE PART

N plano	Firma	Fecha	Aparato	CONDUCCIONES DE AGUA	Lamina	Fagor Industrial S.Coop. FAGOR
C-2410	<i>[Signature]</i>	2009-07	HORNOS COE; VE; VPE 6/11 - 10/11		6	Oñate

MOD.		HORNOS / OVEN		ZONA		CONDUCCIONES DE AGUA / WATER PIPES				PLANO		C-2410	
ITEM	CODIGO	DENOMINACION	TEXTO	COE-061	COE-101	VE-061	VE-101	VPE-061	VPE-101			NOTAS	
S/Nº	1100003163	KIT VALVULA DE LAVADO COMP.	WASHING VALVE KIT	-	-	-	-	1	1				
1	3716000000	TUBO SILICONA Tº Ø 35*27	HIGH SILICON PIPE Tº Ø 35*27	-	-	-	-	1	1				
	Q881305000	ABRAZADERA 25-40	CLAMP 25-40	-	-	-	-	2	2				
2	3676900000	T. GOMA NEGRA Ø17*10 INYECT.	BLACK RUBBER PIPE Ø17*10	1	1	1	1	1	1				
	Q881302000	ABRAZADERA 12*20	CLAMP 12-20	2	2	2	2	2	2				
3	R695003000	MANGUITO CIERRE	CLOSING SLEEVE	1	1	1	1	1	1				
	R695004000	BICONO	BICONE	1	1	1	1	1	1				
4	R095010000	TUBO ENTRADA INYECTOR	INJECTOR PIPE	1	1	-	-	-	-				
4	R695033000	TUBO INYECTOR 6/11	INJECTOR PIPE	-	-	1	1	1	1				
5	R665025000	DISTRIBUIDOR INYECTOR	INJECTOR DISTRIBUTOR	1	1	-	-	-	-				
6	T905004000	INYECTOR COMPLETO HEI 6/11	COMPLETE INJECTOR HEI 6/11	1	-	-	-	-	-				
6	T805002000	INYECTOR COMPLETO HEI 10/11	COMPLETE INJECTOR HEI 10/11	-	1	-	-	-	-				
7	T325066000	JUNTA FIJACION SONDA	PROBE FASTENING SEAL	1	1	1	1	1	1				
	Q232030000	ARANDELA A5	FLAT WASHER A.5	8	8	8	8	8	8				
	Q242030000	ARANDELA ABANICO A5 A.304	FAN SHAPED WASHER A.5	8	8	8	8	8	8				
	Q162030000	TUERCA EXAGONAL M5	HEXAGONAL NUT M.5	8	8	8	8	8	8				
8	Z220901000	BOMBA DESAGÜE 30W	DRAINAGE PUMP 30W	-	-	1	1	1	1				
9	3715900000	TUBO SILICONA Tº Ø 26*18	HIGH SILICON PIPE Tº Ø 26*18	-	-	1	1	1	1				
	Q901311000	ABRAZADERA ELASTICA 26,7*28,1	ELAST. CLAMP 26,7*28,1	-	-	2	2	2	2				
10	T905001000	CHIMENEA COMPLET HEI 6/11	COMPLET FLUEPIPE HEI 6/11	1	-	-	-	-	-				
10	T805001000	CHIMENEA COMPLET HEI 10/11	COMPLET FLUEPIPE HEI 10/11	-	1	-	-	-	-				
10	T915011000	CHIMENEA COMPLET HEM-P 6/11	COMPLET FLUEPIPE HEM-P 6/11	-	-	1	-	1	-				
10	T815011000	CHIMENEA COMPLET HEM-P 10/11	COMPLET FLUEPIPE HEM/P 10/11	-	-	-	1	-	1				
11	T722608000	TUBO FLEXIBLE Ø53X360	FLEXIBLE TUBE Ø53X360	1	1	1	1	1	1				
	Q881307000	ABRAZADERA 40*60	CLAMP 40*60	2	2	2	2	2	2				
12	T915005000	CAJA DESAGÜE LAVADO	COM. DRAINAGE BOX	1	1	1	1	-	-				
12	T825001000	CAJA DESAGÜE LAVADO 6/10/11	COM. DRAINAGE BOX 6/10/11	-	-	-	-	1	1			ELIMINADO 15.11.10	
13	R665080000	CODO DESAGÜE	DRAINAGE L-BEND	1	1	1	1	-	-				
S/Nº	T815001000	CONDUCCIÓN DESAGÜE 6-10/11 E	DRAINAGE DUCT 6-10/11 E	1	1	1	1	-	-			ELIMINADO 02.05.11	
14	T115086000	TOBERA 1/8	NOZZLE 1/8	1	1	1	1	1	1				
15	T325075000	FIJACION SONDA CONDENSADOR	COMPLET. PROBE FASTENING	1	1	1	1	1	1				

MOD.		HORNOS / OVEN		ZONA		CONDUCCIONES DE AGUA / WATER PIPES				PLANO		C-2410	
ITEM	CODIGO	DENOMINACION	TEXTO	COE-061	COE-101	VE-061	VE-101	VPE-061	VPE-101			NOTAS	
16	R662629000	RACORD CIERRE SONDA	PROBE CLOSING ADAPTOR	1	1	1	1	1	1				
	R662652000	BICONO CIERRE SONDA	PROBE CLOSING BICONE	1	1	1	1	1	1				
17	T330723000	CUERPO VALVULA COMPLETO	COMPLETE VALVE BODY	-	-	-	-	1	1				
	Q307080000	JUNTA TORICA Ø52X3,5	O-RING Ø52X3.5	-	-	-	-	1	1				
	Q307079000	JUNTA TORICA Ø33x3,5	O-RING Ø33x3.5	-	-	-	-	1	1				
	T330749000	JUNTA TEFLON VALVULA	TEFLON VALVE BOARD	-	-	-	-	2	2			INTRODUCIDO 02.11.09	
	T330749000	JUNTA TEFLON VALVULA	TEFLON VALVE BOARD	-	-	-	-	1	1			ELIMINADO 10,10,11	
	T330703000	JUNTA TEFLON VALVULA	TEFLON VALVE BOARD	-	-	-	-	2	2			INTRODUCIDO 02.11.09	
	T330703000	JUNTA TEFLON VALVULA	TEFLON VALVE BOARD	-	-	-	-	1	1			ELIMINADO 10,10,11	
18	T330707000	PUNTA ACOPLA MOTOR A VALVUL	CONN. POINT MOTOR TO VALVE	-	-	-	-	1	1				
	Q307084000	JUNTA TORICA Ø11X3.5	O-RING Ø11X3.5	-	-	-	-	1	1			ELIMINADO 10,06,12	
	Q307078000	JUNTA TORICA Ø10x3.5	O-RING Ø10x3.5	-	-	-	-	1	1			INTRODUCIDO 10,06,12	
19	3676900000	TUBO GOMA NEGRA Ø17*10	BLACK RUBBER PIPE Ø17*10	-	-	-	-	1	1				
	Q881302000	ABRAZADERA 12*20	CLAMP 12-20	-	-	-	-	2	2				
20	T330711000	MOTOR VALVULA	VALVE MOTOR	-	-	-	-	1	1				
	Q042022000	TORNILLO AVELLANADO M4X15	COUNTERSUNK SCREW M.4x15	-	-	-	-	2	2				
21	T330733000	CASQUILLO MOTOR MICRO	MICRO MOTOR BUSHING	-	-	-	-	1	1				
	Q151320000	TORNILLO ALOMADO M4X6 H.ZIN.	CURVED SCREW M4X6 H.ZIN.	-	-	-	-	2	2				
	Q371026000	MANGUITO SUJEC. 4X14 DIN1481	HOSE FASTENING 4X14 DIN1481	-	-	-	-	1	1				
	Q052032000	TORNILLO ALLEN M.5x15(+)	ALLEN HEAD SCREW M.5x15(+)	-	-	-	-	2	2				
22	R010535000	PLACA SEPARADORA	SPACER PLATE	-	-	-	-	4	4				
	Q032013000	TORNILLO ALOMADO M3X20	CURVED SCREW M3X20	-	-	-	-	4	4				
	Q221350000	TUERCA AUTOBLOCANTE M3	SELF-LOCKING NUT M3	-	-	-	-	4	4				
23	R010534000	INTERRUPTOR PUERTA	DOOR SWITCH	-	-	-	-	2	2				
24	T330713000	CHAPA SUJECCION MICROS	FASTENING PLATE MICROS	-	-	-	-	1	1			ELIMINADO 01.03.11	
24	T330754000	SOPORTE MICROS LAVADO	MICROS WASH STAND	-	-	-	-	1	1			INTRODUCIDO 01.03.11	
25	T360719000	GOMA VALVULA BOMBA GAS	PUMP VALVE RUBBER GAZ	-	-	-	-	1	1				
	Q881304000	ABRAZADERA 20-32	CLAMP 20-32	-	-	-	-	1	1				
	Q881305000	ABRAZADERA 25-40	CLAMP 25-40	-	-	-	-	1	1				
26	Z258962000	MOTOBOMBA ACLARADO	MOTOR-PUMP	-	-	-	-	1	1			ELIMINADO 01.11.10	
26	Z258976000	MOTOBOMBA ACLARADO	MOTOR-PUMP	-	-	-	-	1	1			INTRODUCIDO 01.11.10	

MOD.		HORNOS / OVEN		ZONA		CONDUCCIONES DE AGUA / WATER PIPES				PLANO		C-2410
ITEM	CODIGO	DENOMINACION	TEXTO	COE-061	COE-101	VE-061	VE-101	VPE-061	VPE-101		NOTAS	
27	T820701000	SOPORTE MOTOBOMBA 6-10/11	MOTOR PUMP SUPPORT 6-10/11	-	-	-	-	1	1		ELIMINADO 01.03.11	
27	T920702000	SOPORTE BOMBA LAVADO	WASH PUMP SUPPORT	-	-	-	-	1	1		INTRODUCIDO 01.03.11	
	Q232030000	ARANDELA A5	FLAT WASHER A.5	-	-	-	-	2	2			
	Q242030000	ARANDELA ABANICO A5 A.304	FAN SHAPED WASHER A.5	-	-	-	-	2	2			
	Q012032000	TORNILLO EXAGONAL M5x15 A304	HEXAGONAL SCREW M.5x15	-	-	-	-	2	2			
28	T325063000	ENTRADA DE AGUA COMPLETA	COMPLETE WATER INLET	-	-	1	1	1	1		ELIMINADO 01.04.10	
28	T645006000	ENTRADA DE AGUA COMPLETA	COMPLETE WATER INLET	-	-	1	1	1	1		INTRODUCIDO 01.04.10	
	Q307031000	JUNTA TUBO 14X24X3	JOINT 14X24X3	-	-	2	2	2	2			
	Q012021000	TORNILLO EXAGONAL M4x10 A304	HEXAGONAL BOLT M4x10 A304	-	-	2	2	2	2			
	Q242010000	ARANDELA ABANICO A3 A.304	FAN SHAPED WASHER A.3	-	-	2	2	2	2			
	Q162020000	TUERCA EXAGONAL M4	HEXAGONAL NUT M.4º	-	-	2	2	2	2			
29	Z701135000	ELECTROVALVUL. SIMPLE 255.208	SIMPLE SOLENOID VALVE	1	1	-	-	-	-			
29	Z701135000	ELECTROVALVUL. SIMPLE 255.208	SIMPLE SOLENOID VALVE	-	-	1	1	1	1		ELIMINADO 01.04.10	
30	P443042000	REGULADOR 3 L. VERDE 254.023	REGULATOR 3 L. GREEN	1	1	1	1	1	1			
31	3676900000	T. GOMA NEGRA Ø17*10 CONDEN.	BLACK RUBBER PIPE Ø17*10	1	1	1	1	1	1			
	Q881302000	ABRAZADERA 12*20	CLAMP 12-20	2	2	2	2	2	2			
32	P255001000	ELECTROVALVULA DOBLE	DOUBLE SOLENOID VALVE	1	1	1	1	1	1		ELIMINADO 14.12.09	
32	Z701135000	ELECTR. SIMP.220V COD.255.208	SOLENOID VALVE SIMP.220V CO	1	1	-	-	-	-		INTRODUCIDO 14.12.09	
32	Z611123000	ELECTR. TRIPLE COD.255.641	TRIPLE SOLENOID VALVE 255.6	-	-	1	1	1	1		INTRODUCIDO 01.04.10	
33	R665041000	REGULADOR 0.25L. ROJO	REGULATOR 0.25L. RED	1	1	1	1	1	1			
S/Nº	Z233012000	CONDENSADOR ANTIPARASIT.	ANTIPARASIT. CONDENS.	3	3	4	4	4	4		INTRODUCIDO 03.05.10	

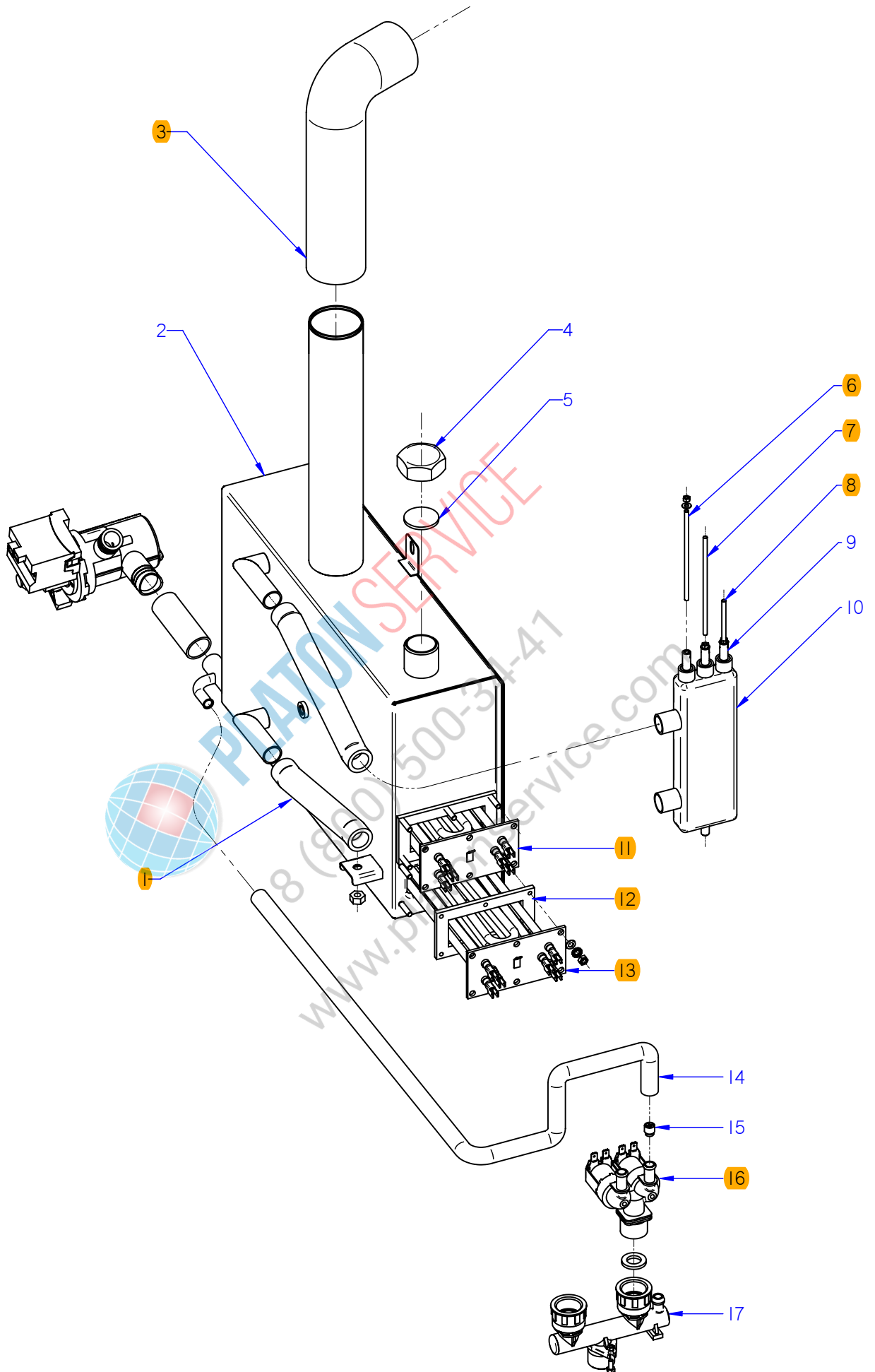

ITEM MARCADO EN COLOR = REPUESTO RECOMENDADO
 COLOURED ITEM = RECOMMENDED SPARE PART

N plano	Firma	Fecha	Aparato	CIRCUITO DE VAPOR	Lamina	Fagor Industrial S.Coop. FAGOR
C-2411	<i>name Benjo</i>	2009-07	HORNOS VE; VPE 061 / 101		7	Oñate

MOD.		HORNOS / OVEN		ZONA		CIRCUITO DE VAPOR / STEAM CIRCUIT		PLANO		C-2411	
ITEM	CODIGO	DENOMINACION	TEXTO	VE-061	VE-101	VPE-061	VPE-101				NOTAS
1	3715900000	TUBO SILICONA T° Ø 26*18	HIGH SILICON PIPE T° Ø 26*18	3	3	3	3				
	Q901311000	ABRAZADERA ELASTICA 26,7*28,1	ELAST. CLAMP 26,7*28,1	6	6	6	6				
2	1100003140	KIT GENERADOR VAPOR 6/11	STEAM GENERATOR 6/11 KIT	1	-	1	-				
2	1100003142	KIT GENERADOR VAPOR 10-20/11	STEAM GENERATOR 10-20 KIT	-	1	-	1				
3	T722608000	TUBO FLEXIBLE Ø53X360	FLEXIBLE TUBE Ø53X360	1	1	1	1				ELIMINADO 28,06,11
3	12041855	TUBO FLEXIBLE Ø53X360 VARIL INC	FLEXIBLE TUBE Ø53X360	1	1	1	1				INTRODUCIDO 28,06,11
	Q881307000	ABRAZADERA 40*60	CLAMP 40*60	2	2	2	2				
4	R015010000	TUERCA TAPON 1"	PLUG NUT 1"	1	1	1	1				
5	R015011000	ARANDELA Ø32	WASHER Ø32	1	1	1	1				
6	R345060000	ELECTRODO ALTO	HIGH LEVEL ELECTRODE	1	1	1	1				
7	R345063000	ELECTRODO BAJO	LOW LEVEL ELECTRODE	1	1	1	1				
8	R345064000	ELECTRODO DE MASA	EARTH ELECTRODE	1	1	1	1				
	Q232020000	ARANDELA A4	FLAT WASHER A.4	3	3	3	3				
	Q162020000	TUERCA EXAGONAL M4	HEXAGONAL NUT M.4°	3	3	3	3				
9	R345069000	GUIA AISLANTE	INSULATION GUIDE	3	3	3	3				
10	T325077000	BOTE DE NIVELES	LEVELS VESSEL	1	1	1	1				ELIMINADO 13.09.10
10	T325079000	BOTE DE NIVELES	LEVELS VESSEL	1	1	1	1				INTRODUCIDO 13.09.10
	Q228051000	TUERCA EXAGONAL M8 PLASTIC	HEXAGONAL NUT M8 PLASTIC	1	1	1	1				
11	R143033000	RESISTENCIA 3x3000W 230V	RESISTOR 3x3000W 230V	1	1	1	1				
12	R145012000	JUNTA CIERRE RESISTENCIAS	RESISTOR SEAL	1	2	1	2				
	Q242030000	ARANDELA ABANICO A5 A.304	FAN SHAPED WASHER A.5	6	12	6	12				
	Q163030000	TUERCA EXAGONAL M5 LATON	HEXAGONAL NUT M5	6	12	6	12				
13	R143000000	RESISTENCIA 3x3000W	RESISTOR 3x3000W	-	1	-	1				
14	3676900000	T. GOMA NEGRA Ø17*10	BLACK RUBBER PIPE Ø17*10	1	1	1	1				
	Q881302000	ABRAZADERA 12*20	CLAMP 12-20	2	2	2	2				
15	Z601156000	REGULADOR 8L RO 254.034	REGULATOR 8L RED 254.034	1	1	1	1				
16	P255001000	ELECTROVALVULA DOBLE	DOUBLE SOLENOID VALVE	1	1	1	1				ELIMINADO 14.12.09
16	Z611123000	ELECTR. TRIPLE COD.255.641	TRIPLE SOLENOID VALVE 255.6	1	1	1	1				INTRODUCIDO 01.04.10
17	T325063000	ENTRADA DE AGUA COMPLETA	COMPLETE WATER INLET	1	1	1	1				ELIMINADO 01.04.10
17	T645006000	ENTRADA DE AGUA COMPLETA	COMPLETE WATER INLET	1	1	1	1				INTRODUCIDO 01.04.10
	Q307031000	JUNTA TUBO 14X24X3	JOINT 14X24X3	2	2	2	2				

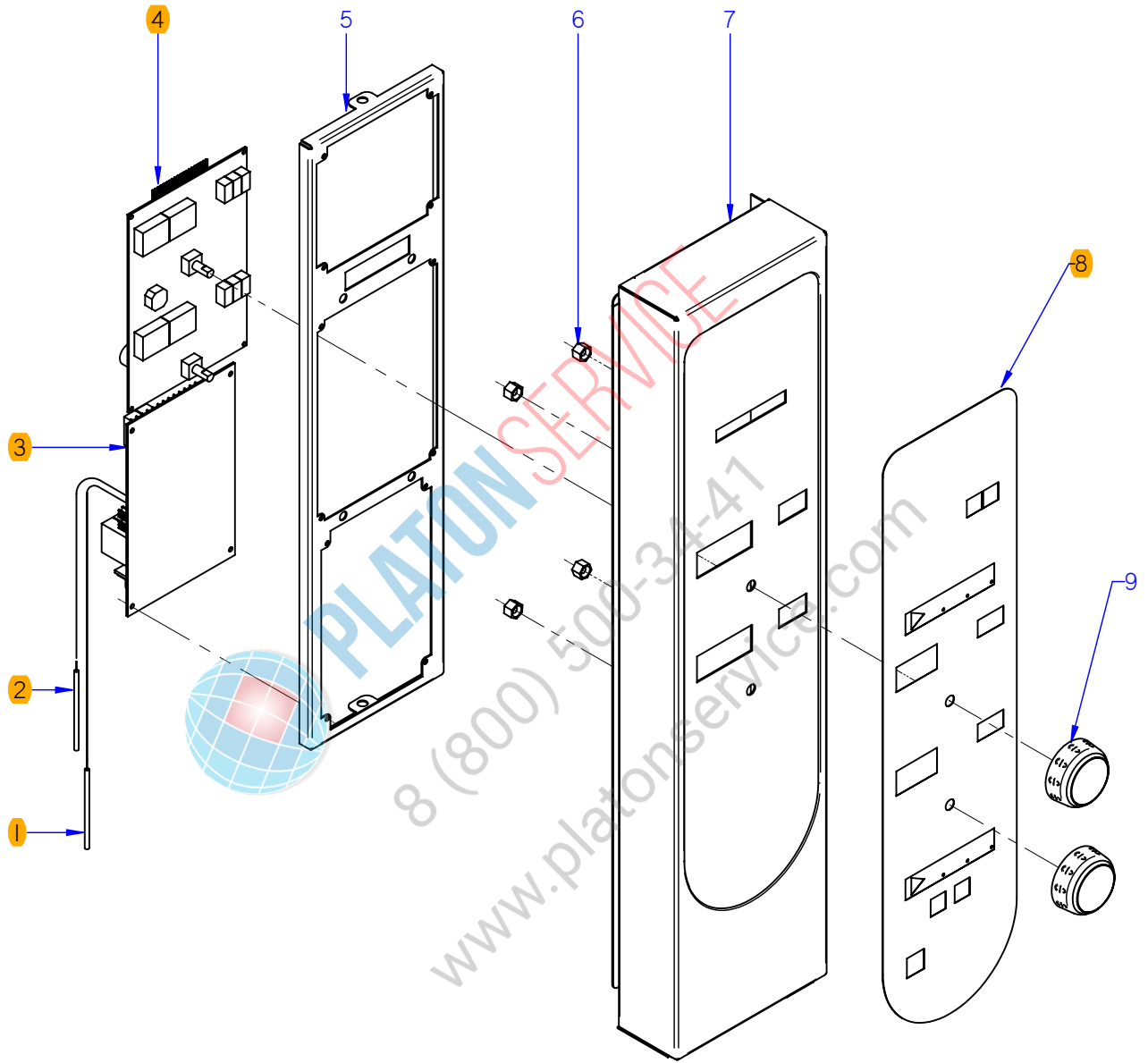

ITEM MARCADO EN COLOR = REPUESTO RECOMENDADO
 COLOURED ITEM = RECOMMENDED SPARE PART

N plano	Firma	Fecha	Aparato	Lamina	Fagor Industrial S.Coop. FAGOR
C-2412	<i>[Signature]</i>	2009-07	CONJUNTO ELECTRICO PORTAMANDOS HORNOS COE 061 / 101	8	Oñate

MOD.		HORNOS / OVEN		ZONA	CONJUNTO ELECTRICO PORTAMANDOS / CONTROL HOLDER ELECTRIC UNIT			PLANO	C-2412
ITEM	CODIGO	DENOMINACION	TEXTO	COE-061	COE-101				NOTAS
1	T323011000	CONJUN. TERMOPAR CAMARA (K)	CHAMBER THERMOCOUPLE UNIT	1	1				
2	T323024000	CONJUN. TERMOPAR VAPOR 10/21	STEAM THERMOCOUPLE UNIT 1	1	1				
3	T553003000	TARJETA CONTROL DE CAMARA	CHAMBER CONTROL CARD	1	1				ELIMINADO 16,11,11
3	12046659	CONTROL TARJETA CAM.12V AC .	CARD CONTROL 12V AC 50/60Hz	1	1				INTRODUCIDO 16,11,11
	Q221023000	CLIP SUJECIÓN RÁPIDA Ø 4	RAPID CONNECT CLIP Ø 4	8	8				
4	T533001000	TARJETA PORTAMANDOS HEI-HGC	CONTROL PANEL CARD	1	1				ELIMINADO 16,11,11
4	12046671	VISUALIZADOR 12V AC 50/60Hz 12D	12V AC 50/60Hz 12D DISPLAY	1	1				INTRODUCIDO 16,11,11
5	T932802000	SOPORTE PROGRAMADOR	CIRCUIT SUPPORT	1	1				
6	T732802000	DISTANCIAD. COMPONENTES 7mm	SPACER 7mm	4	4				
7	T902808000	PANEL PORTAMANDO 6-11 HEI	CONTROL PANEL 6-11 HEI	1	-				
7	T802802000	PANEL PORTAMANDOS 10-11 HEI	CONTROL PANEL 10-11 HEI	-	1				
	Q221342000	REMACHE EXAGONAL M5	HEXAGONAL RIVET M.5	3	3				
8	T903010000	SERIGRAFIA HEI 6-10-20/11	SERIGRAPHY HEI 6-10-20/11	1	1				
9	T903007000	BOTON DE MANDO	CONTROL BUTTON	2	2				

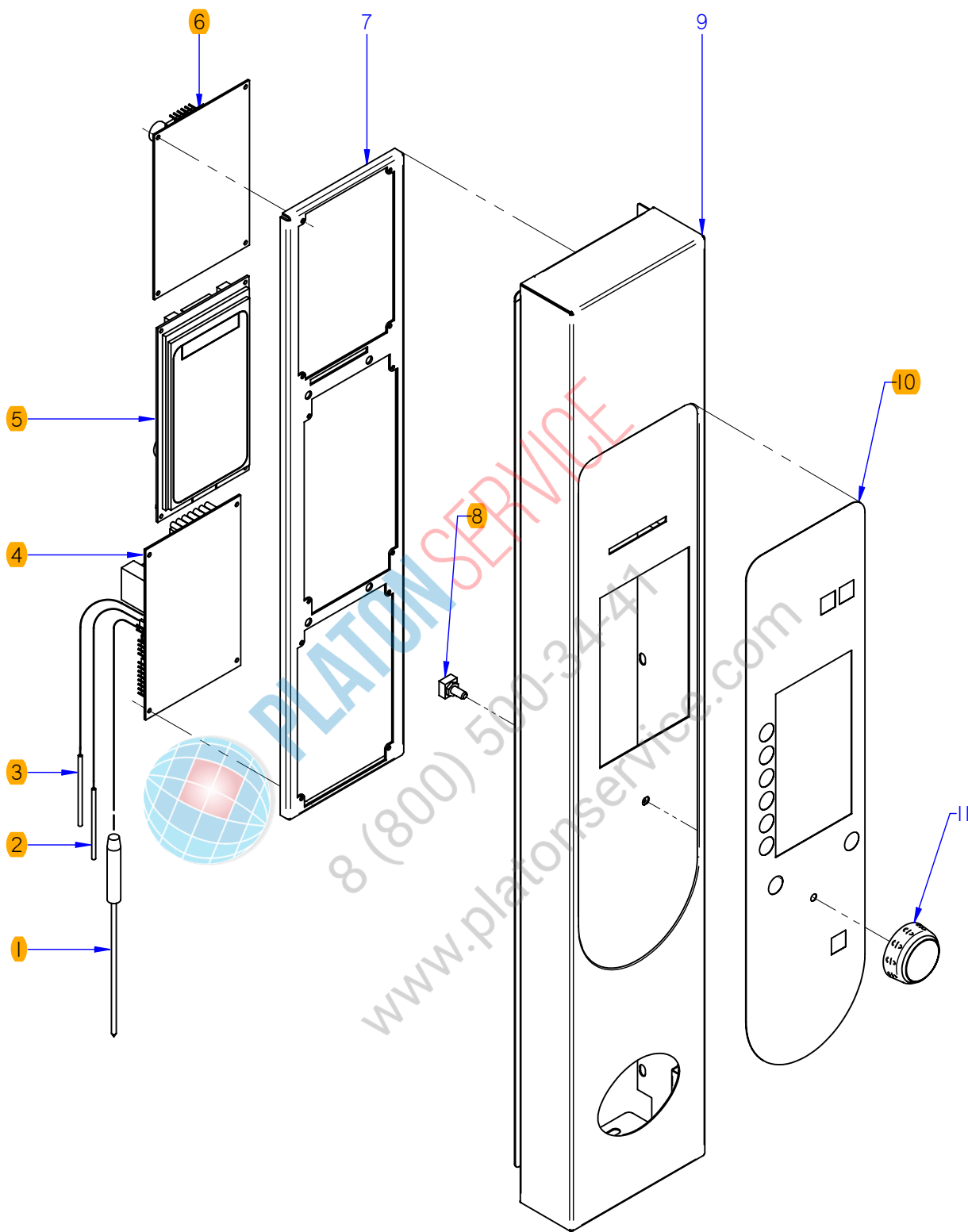

ITEM MARCADO EN COLOR = REPUESTO RECOMENDADO
 COLOURED ITEM = RECOMMENDED SPARE PART

N plano	Firma	Fecha	Aparato	CONJUNTO ELECTRICO PORTAMANDOS	Lamina	Fagor Industrial S.Coop. FAGOR
C-2413	<i>[Signature]</i>	2009-07	HORNOS VE-061 /101		9	Oñate

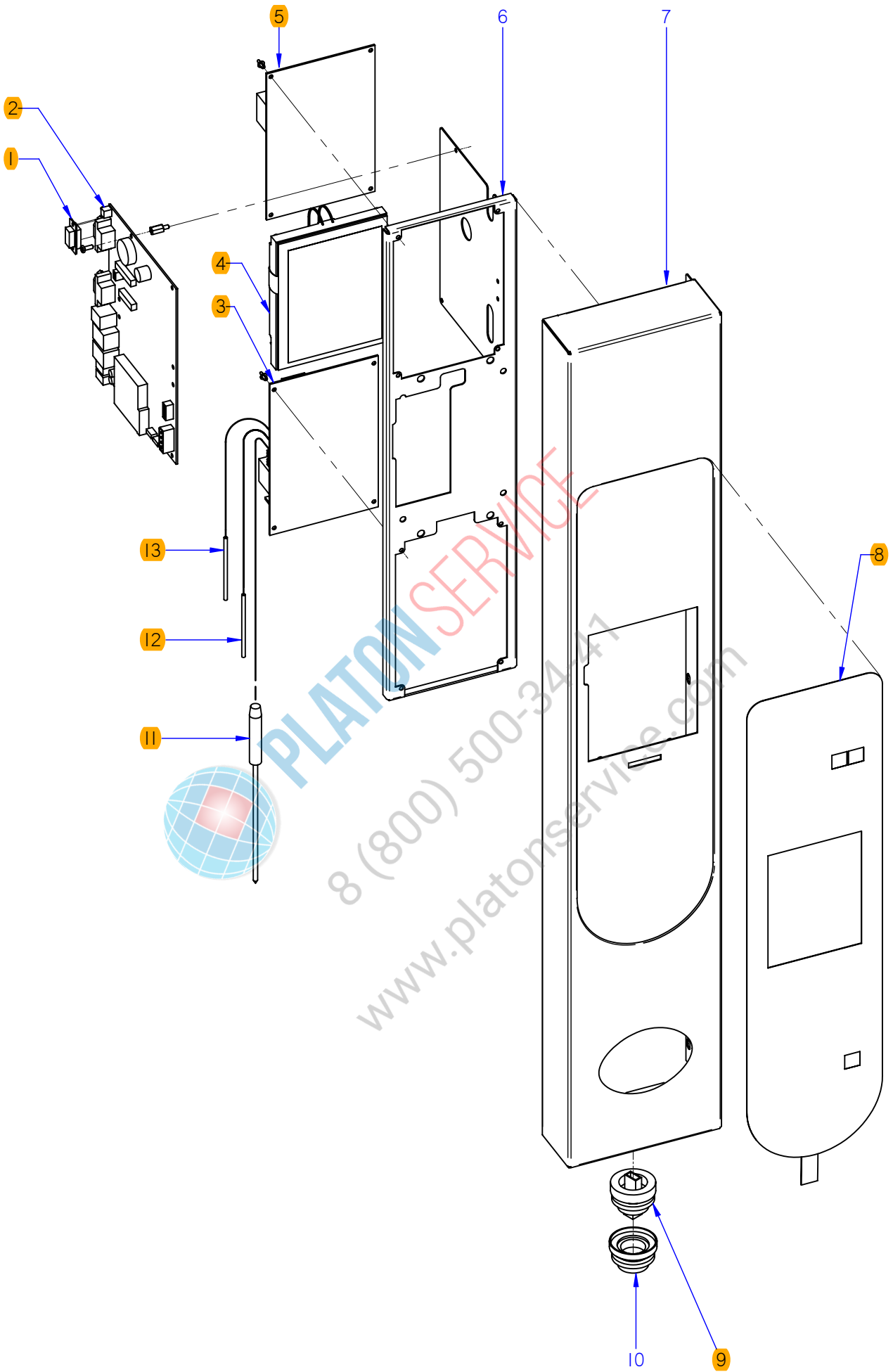

ITEM MARCADO EN COLOR = REPUESTO RECOMENDADO
 COLOURED ITEM = RECOMMENDED SPARE PART

N plano	Firma	Fecha	Aparato	CONJUNTO ELECTRICO PORTAMANDOS	Lamina	Fagor Industrial S.Coop. FAGOR
C-2414	<i>[Signature]</i>	2009-07	HORNOS VPE-061 / 101		10	Oñate

MOD.		HORNOS / OVEN		ZONA		CONJUNTO ELECTRICO PORTAMANDOS / CONTROL HOLDER ELECTRIC UNIT				PLANO		C-2414	
ITEM	CODIGO	DENOMINACION	TEXTO	VPE-061	VPE-101							NOTAS	
1	T553007000	MOCHILA BMF	DONGLE BMF	1	1							ELIMINADO 15.06.10	
2	T553001000	CIRC. PORTAMANDOS GAMA ALTA	CONTROL HOLDER CIRC. HIGH P	1	1							ELIMINADO 15.06.10	
	T133007000	DISTANCIADOR M3	SPACER M3	6	6								
	T133008000	TORNILLO AMARRE M3	ANCHORING SCREW M3	6	6								
	Q161310000	TUERCA EXAGONAL M3 H. ZINC,	HEXAGONAL NUT M3 H. ZINC,	6	6								
3	T553003000	TARJETA CONTROL DE CAMARA	CHAMBER CONTROL CARD	1	1							ELIMINADO 16,11,11	
3	12046659	CONTROL TARJETA CAM.12V AC .	CARD CONTROL 12V AC 50/60Hz	1	1							INTRODUCIDO 16,11,11	
	Q221023000	CLIP SUJECIÓN RÁPIDA Ø 4	RAPID CONNECT CLIP Ø 4	4	4								
4	T823007000	PANTALLA TACTIL 5,7	TOUCH SCREEN 5.7	1	1							ELIMINADO 15.06.10	
4	T553010000	PLATAFORMA VISUAL PLUS	VISUAL PLUS PLATFORM	1	1							INTRODUCIDO 15.06.10	
5	T553002000	TARJETA CONTROL CALDERA	BOILER CONTROL CARD	1	1							ELIMINADO 16,11,11	
5	12046670	CONTROL TARJETA CALD. 12V AC 5	CARD CONTROL 12V AC 50/60Hz	1	1							INTRODUCIDO 16,11,11	
	Q221023000	CLIP SUJECIÓN RÁPIDA Ø 4	RAPID CONNECT CLIP Ø 4	4	4								
6	T822804000	SOPORTE CIRCUITOS HEP	CIRCUIT SUPPORT HEP	1	1							ELIMINADO 15.06.10	
6	T922807000	SOPORTE CIRCUITOS VPE-061	CIRCUIT SUPPORT VPE-061	1	-							INTRODUCIDO 15.06.10	
6	T822815000	SOPORTE CIRCUITOS VPE-X11	CIRCUIT SUPPORT VPE-X11	-	1							INTRODUCIDO 15.06.10	
	Q232030000	ARANDELA A5	FLAT WASHER A.5	4	4								
	Q221308000	TUERCA EXAGONAL AUT M5 H. ZI.	HEXAGONAL NUT M5 H. ZINC,	4	4								
7	T922804000	PANEL PORTAMANDO 6-11 HEP	CONTROL PANEL 6-11 HEP	1	-							ELIMINADO 15.06.10	
7	T922806000	PANEL PORTAMANDO VPE-061	CONTROL PANEL VPE-061	1	-							INTRODUCIDO 15.06.10	
7	T822803000	PANEL PORTAMANDO 10-11 HEP	CONTROL PANEL 10-11 HEP	-	1							ELIMINADO 15.06.10	
7	T822814000	PANEL PORTAMANDO VPE-101	CONTROL PANEL VPE-101	-	1							INTRODUCIDO 15.06.10	
	Q221342000	REMACHE EXAGONAL M5	HEXAGONAL RIVET M.5	3	3								
8	T823008000	SERIGRAFIA HEP	SERIGRAPHY HEP	1	1							ELIMINADO 15.06.10	
8	T823013000	SERIGRAFIA VPE	SERIGRAPHY VPE	1	1							ELIMINADO 01.12.10	
8	T823019000	SERIGRAFIA VPE-11 16/9	SERIGRAPHY VPE-11 16/9	1	1							INTRODUCIDO 01.12.10	
9	T723006000	CONECTOR USB VISUAL PLUS	VISUAL PLUS USB CONNECTOR	1	1								
10	T723007000	TAPA USB VISUAL PLUS	VISUAL PLUS USB COVER	1	1								
11	T823009000	CONJUN. SONDA NUCLEO (K) 6 PU	PROBE UNIT FOR CORE	1	1								
12	T323011000	CONJUN. TERMOPAR CAMARA (K)	CHAMBER THERMOCOUPLE UNI	1	1								
13	T323024000	CONJUN. TERMOPAR VAPOR 10/21	STEAM THERMOCOUPLE UNIT 1	2	2								

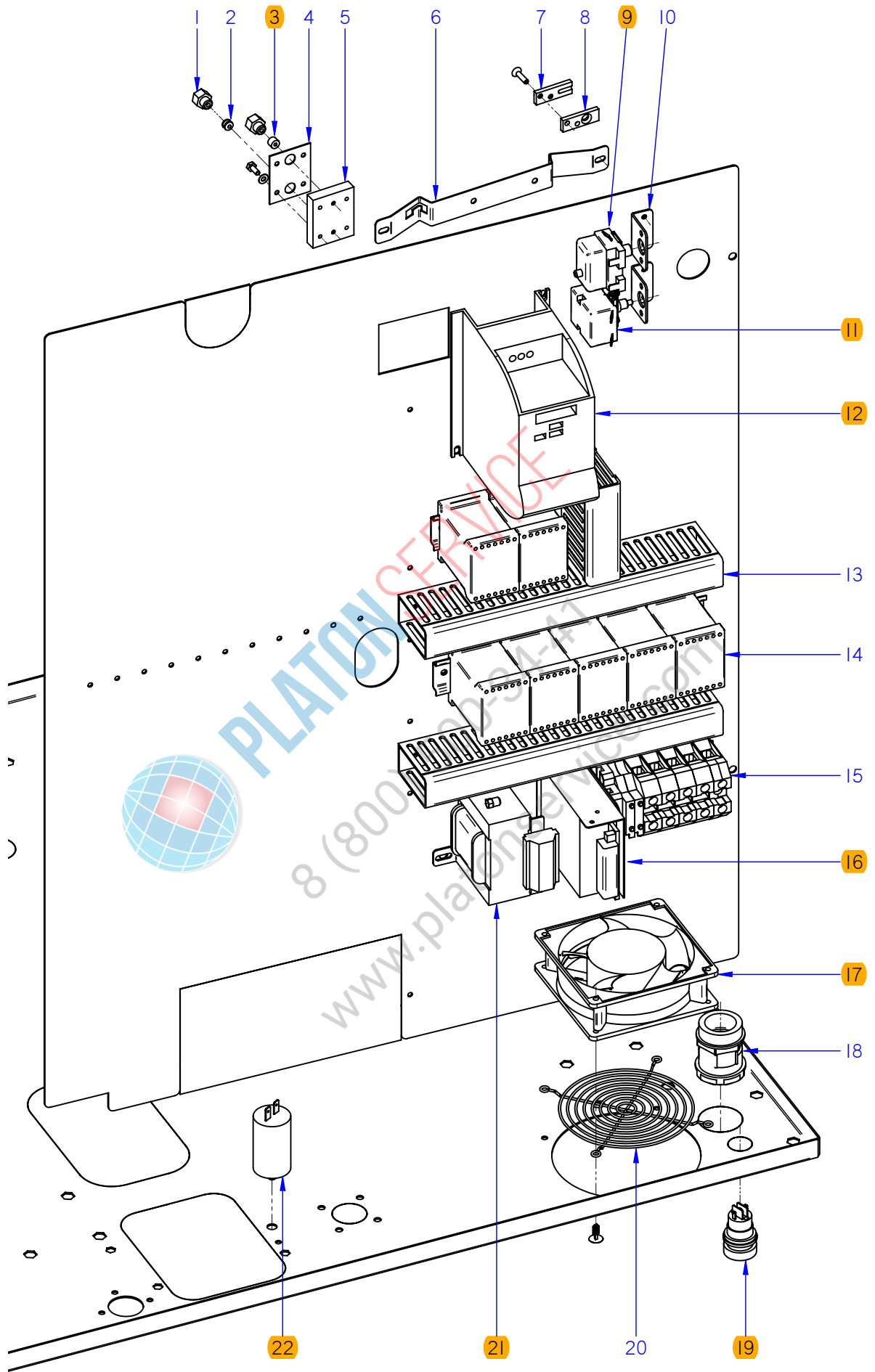

ITEM MARCADO EN COLOR = REPUESTO RECOMENDADO
 COLOURED ITEM = RECOMMENDED SPARE PART

N plano	Firma	Fecha	Aparato	CUADRO ELECTRICO	Lamina	Fagor Industrial S.Coop. FAGOR
C-2415	<i>(Signature)</i>	2009-07	HORNOS COE; VE; VPE 061 / 101	11	Oñate	

MOD.		HORNOS / OVEN		ZONA		CUADRO ELECTRICO / ELECTRIC PANEL				PLANO		C-2415	
ITEM	CODIGO	DENOMINACION	TEXTO	COE-061	COE-101	VE-061	VE-101	VPE-061	VPE-101			NOTAS	
1	R662629000	RACORD CIERRE SONDA	PROBE CLOSING ADAPTOR	2	2	2	2	2	2				
2	R662652000	BICONO CIERRE SONDA	PROBE CLOSING BICONE	1	1	1	1	1	1				
3	R662662000	JUNTA CIERRE BULBO LIMITADOR	BULB LIMITER CLOSING SEAL	1	1	1	1	1	1				
4	R692811000	JUNTA PASAMUROS DOBLE	FEEDTHROUGH SEAL	1	1	1	1	1	1				
	Q232020000	ARANDELA A4	FLAT WASHER A.4	4	4	4	4	4	4				
	Q012021000	TORNILLO EXAGONAL M4X10	HEXAGONAL BOLT M4X10	4	4	4	4	4	4				
5	R662659000	APOYO RACORD SONDA	PROBE RACORD SUPPORT	1	1	1	1	1	1				
6	R662683000	SOPORTE BULBO	BULB SUPPORT	1	1	1	1	1	1				
	Q412002000	REMACHE AVINOX Ø4x10MM	TUBULAR RIVET 4x7,5	4	4	4	4	4	4				
7	T133037000	TAPA SUJECION SONDA	COVER CORE PROBE	1	1	-	-	-	-			ELIMINADO 01.09.09	
7	T133037000	TAPA SUJECION SONDA	COVER CORE PROBE	-	-	1	1	1	1				
	Q042022000	TORNILLO AVELLANADO M4X15	BOLT M4X15	2	2	2	2	2	2				
8	T133036000	BASE SUJECION SONDA	FIXING CORE PROBE	-	-	1	1	1	1				
9	Z953035000	TERMOSTATO LIMITADOR AVISO	LIMITER THERMOSTAT WARNIN	-	-	1	1	1	1				
	Z953041000	TUERCA M.10x1 EGO 00.00600.075	NUT M.10x1 EGO 00.00600.075	1	1	2	2	2	2				
10	R343039000	SOPORTE TERMOS VAPOR	THERMOSTAT SUPPORT	1	1	2	2	2	2				
	Q412002000	REMACHE AVINOX Ø4x10MM	TUBULAR RIVET 4x7,5	1	1	2	2	2	2				
11	T303009000	TERMOSTATO LIMITADOR	THERMOSTAT LIMITER	1	1	1	1	1	1				
12	T323037000	VARIADOR FRECUENCIA SIE 0,37	FREQUENCY VARIATOR SIE 0.37	1	1	1	1	1	1				
	Q232020000	ARANDELA A4	FLAT WASHER A.4	6	6	6	6	6	6				
	Q242020000	ARANDELA ABANICO A4 A.304	FAN SHAPED WASHER A.4	6	6	6	6	6	6				
	Q032021000	TORNILLO ALOMADO M4X10	CURVED SCREW M.4x10	6	6	6	6	6	6				
13	3715520000	CANALETA UNEX 60.30.77 / 0.12	PIPING UNEX 60.30.77 / 0.12	3	3	3	7	3	7				
	Q412002000	REMACHE AVINOX Ø4x10MM	TUBULAR RIVET 4x7,5	18	15	18	20	18	20				
	Q221341000	REMACHE EXAGONAL M.4	HEXAGONAL RIVET M.4	6	6	6	6	6	6				
14	Z203050000	CONTAC. SIRIUS 3R 230V.50-60	SIRIUS 3R 230V.50-60 CONTAC.	1	1	1	1	1	1			ELIMINADO 01.09.09	
14	Z213007000	CONTACTOR 230V.50-60	230V.50-60 CONTACTOR	1	1	1	1	1	1			INTRODUCIDO 01.09.09	
14	Z203050000	CONTAC. SIRIUS 3R 230V.50-60	SIRIUS 3R 230V.50-60 CONTAC.	2	4	3	6	3	6				
	Z403016000	GUIA CONTACTOR L-100	CONTACTOR GUIDE L-100	1	1	1	1	1	1				
	R693009000	GUIA CONTACTOR L-250	CONTACTOR GUIDE L=250	1	1	1	1	1	1				

MOD.		HORNOS / OVEN		ZONA		CUADRO ELECTRICO / ELECTRIC PANEL				PLANO		C-2415	
ITEM	CODIGO	DENOMINACION	TEXTO	COE-061	COE-101	VE-061	VE-101	VPE-061	VPE-101			NOTAS	
15	R263003000	BORNA PASO 35MM	GREY PHASE 35 TERMINAL	3	-	3	-	3	-			ELIMINADO 01.10.10	
15	R263003000	BORNA PASO 35MM	GREY PHASE 35 TERMINAL	-	3	-	3	-	3				
15	P453025000	BORNA 10 WDU-10203.O	10 WDU-10203.O TERMINAL	3	-	3	-	3	-			INTRODUCIDO 01.10.10	
	R673010000	BORNA PASO AZUL 35MM	NEUTRAL TERMINAL 35 BLUE	1	-	1	-	1	-			ELIMINADO 21.09.10	
	R673010000	BORNA PASO AZUL 35MM	NEUTRAL TERMINAL 35 BLUE	-	1	-	1	-	1				
	Z263302000	BORNA PASO AZUL	NEUTRAL TERMINAL	1	-	1	-	1	-			INTRODUCIDO 01.10.10	
	Z103035000	BORNA TIERRA 35MM	EARTH TERMINAL 35mm	1	-	1	-	1	-			ELIMINADO 01.10.10	
	Z103035000	BORNA TIERRA 35MM	EARTH TERMINAL 35mm	-	1	-	1	-	1				
	P453026000	BORNA TIERRA 10 WPE-10103.O	EARTH TERMINAL 10 WPE-101	1	-	1	-	1	-			INTRODUCIDO 01.10.10	
	R073005000	BORNA PORTAFUSIBLES	FUSE HOLDER TERMINAL	2	2	2	2	2	2				
	Z263303000	TOPE FINAL	END BUFFER	2	2	2	2	2	1			ELIMINADO 01.10.10	
	R663055000	GUIA CONTACTOR L-120	CONTACTOR GUIDE L=120	1	1	1	1	1	1				
16	T553005000	ALIMENT PORTAMAN VISUAL PLUS	VISUAL PLUS CONTROL HOLDER	-	-	-	-	1	1			ELIMINADO 15.06.10	
S/Nº	T553008000	SOPORTE ALIMENTACION	POWER SUPPLY SUPPORT	-	-	-	-	1	1			ELIMINADO 15.06.10	
17	Z103066000	VENTILADOR 230V.50-60HZ	FAN 230V 50/60HZ	1	1	1	1	1	1				
17	Z103066000	VENTILADOR 230V.50-60HZ	FAN 230V 50/60HZ	1	1	1	1	1	1			ELIMINADO 01.03.11	
18	R033002000	PRENSA ESTOPAS	STUFFING BOX	1	-	1	-	1	-			ELIMINADO 01.07.10	
18	R023013000	PRENSA ESTOPAS PG-21	STUFFING BOX PG-21	1	-	1	-	1	-			INTRODUCIDO 01.07.10	
18	R033002000	PRENSA ESTOPAS	STUFFING BOX	-	1	-	1	-	1				
	R033025000	CONTRATUERCA (GAES)	COUNTERNUT (GAES)	1	-	1	-	1	-			ELIMINADO 01.07.10	
	R023025000	CONTRATUERCA (GAES)	COUNTERNUT (GAES)	1	-	1	-	1	-			INTRODUCIDO 01.07.10	
	R033025000	CONTRATUERCA (GAES)	COUNTERNUT (GAES)	-	1	-	1	-	1				
19	T723009000	PULSADOR SERIE MICRO	MICRO SWITCH SERIES	-	-	-	-	1	1			INTRODUCIDO 15.11.09	
20	T113015000	PROTECCION VENTILADOR	FAN PROTECTION	1	1	1	1	1	1				
20	T113015000	PROTECCION VENTILADOR	FAN PROTECTION	1	1	1	1	1	1			ELIMINADO 01.04.11	
	Q418022000	REMACHE NYLON 4x15	TUBULAR RIVET NYLON 4x15	4	4	4	4	4	4				
	Q031322000	TORNILLO ALOMADO M4x15	CURVED SCREW M.4x15	4	4	4	4	4	4				
	Q232020000	ARANDELA A4	FLAT WASHER A.4	4	4	4	4	4	4				
	Q162020000	TUERCA EXAGONAL M4	HEXAGONAL NUT M.4	4	4	4	4	4	4				

MOD.		HORNOS / OVEN		ZONA		VARIOS / MISCELLANEOUS				PLANO	
ITEM	CODIGO	DENOMINACION	TEXTO	COE-061	COE-101	VE-061	VE-101	VPE-061	VPE-101		
	T906501000	MANUAL DE INSTRUCCIONES COE	INSTRUCTIO. BROCHURE COE	1	1	-	-	-	-		
	T916501000	MANUAL DE INSTRUCCIONES VE	INSTRUCTIO. BROCHURE VE	-	-	1	1	-	-		
	T926501000	MANUAL DE INSTRUCCIONES VPE	INSTRUCTIO. BROCHURE VPE	-	-	-	-	1	1		
	T903001000	ESQUEMA TEORICO E 6/11	THEORETICAL DIAGRAM E 6/11	1	-	-	-	-	-	HC-80555 ELIMINADO 01.10.10	
	T803003000	ESQUEMA TEORICO HEI 10/11	THEORETICAL DIAGRAM HEI 10	-	1	-	-	-	-	HC-80669 ELIMINADO 01.10.10	
	T913001000	ESQUEMA TEORICO E 6/11	THEORETICAL DIAGRAM E 6/11	-	-	1	-	-	-	HC-80785 ELIMINADO 01.10.10	
	T813003000	ESQUEMA TEORICO E 10/11	THEORETICAL DIAGRAM E 10/11	-	-	-	1	-	-	HC-80788 ELIMINADO 01.10.10	
	T923003000	ESQUEMA TEORICO VPE-061	THEORETICAL DIAGRAM VPE-06	-	-	-	-	1	-	HC-80762 ELIMINADO 01.10.10	
	T823001000	ESQUEMA TEORICO VPE-101	THEORETICAL DIAGRAM VPE-10	-	-	-	-	-	1	HC-80754 ELIMINADO 01.10.10	
	T923015000	ESQUEMA TEORIC COE VE VPE	THEOR. DIAGRAM COE VE VPE	1	1	1	1	1	1	HC-82334 INTRODUCIDO 01.10.10	
	T903002000	PLANO DE MONTAJE E 6/11	ASSEMBLY PLAN E 6/11	1	-	-	-	-	-	HC-80556 ELIMINADO 01.10.10	
	T803004000	PLANO DE MONTAJE HEI10/11	ASSEMBLY PLAN HEI10/11	-	1	-	-	-	-	HC-80670 ELIMINADO 01.10.10	
	T913002000	PLANO DE MONTAJE E 6/11	ASSEMBLY PLAN E 6/11	-	-	1	-	-	-	HC-80786 ELIMINADO 01.10.10	
	T813002000	PLANO DE MONTAJE E 10/11	ASSEMBLY PLAN E 10/11	-	-	-	1	-	-	HC-80787 ELIMINADO 01.10.10	
	T923002000	PLANO DE MONTAJE VPE-061	ASSEMBLY PLAN VPE-061	-	-	-	-	1	-	HC-80761 ELIMINADO 01.10.10	
	T823002000	PLANO DE MONTAJE VPE-101	ASSEMBLY PLAN VPE-101	-	-	-	-	-	1	HC-80755 ELIMINADO 01.10.10	
	T923055000	PLANO DE MONTAJE VPE 061	ASSEMBLY PLAN VPE 061	1	-	1	-	1	-	HD-13201 INTRODUCIDO 01.10.10	
	T823018000	PLANO DE MONTAJE VPE 10 1	ASSEMBLY PLAN VPE 10 1	-	1	-	1	-	1	HD-13202 INTRODUCIDO 01.10.10	
	T903006000	CABLEADO COMUNICACION BMF	COMMUNICATION WIRING BMF	1	1	1	1	1	1	ELIMINADO 14.06.10	
	T923016000	CABLEADO BMF	WIRING BMF	1	1	1	1	1	1	INTRODUCIDO 14.06.10	
	T903011000	CABLEADO LUZ INTERIOR	INTERIOR LIGHT WIRING	1	-	1	-	1	-	ELIMINADO 01.10.10	
	T903011000	CABLEADO LUZ INTERIOR 6/11	INTERIOR LIGHT WIRING6/11	1	-	1	-	1	-	INTRODUCIDO 03.05.11	
	T903011000	CABLEADO LUZ INTERIOR	INTERIOR LIGHT WIRING	-	1	-	1	-	1		
	T903004000	CABLEADO VARIADOR CONCEPT	CONCEPT VARIATOR WIRING	1	1	1	-	1	-	ELIMINADO 01.10.10	
	T823006000	CABLEADO VARIADOR VISUAL	STEAM WIRING VPE-101	-	-	-	1	-	1	ELIMINADO 01.10.10	
	T903005000	CABLEADO FUERZA COE-6/11	POWER WIRE COE-6/11	1	-	-	-	-	-	ELIMINADO 01.10.10	
	T803001000	CABLEADO FUERZA COE-101	POWER WIRE COE-101	-	1	-	-	-	-	ELIMINADO 01.10.10	
	T803006000	CABLEADO FUERZA COE-101	POWER WIRE COE-101	-	1	-	-	-	-	INTRODUCIDO 01.10.10	
	T923005000	CABLEADO FUERZA VPE-061	POWER WIRE VPE VPE-061	-	-	1	-	1	-	ELIMINADO 01.10.10	
	T823004000	CABLEADO FUERZA VPE-101	POWER WIRE VPE VPE-101	-	-	-	1	-	1	ELIMINADO 01.10.10	
	T823016000	CABLEADO FUERZA VPE-101	POWER WIRE VPE VPE-101	-	-	-	1	-	1	INTRODUCIDO 01.10.10	

MOD.		HORNOS / OVEN		ZONA	VARIOS / MISCELLANEOUS					PLANO
ITEM	CODIGO	DENOMINACION	TEXTO	COE-061	COE-101	VE-061	VE-101	VPE-061	VPE-101	
	T803002000	CABLEADO CONVECCION:HEI10/11	CONVECTION WIRING: HEI10/11	-	1	-	-	-	-	ELIMINADO 01.10.10
	T913006000	CAB CIRCUIT PORTAMANDOS VIS.	VIS. CONTROL HOLDER CIRCUIT	-	-	1	1	-	-	ELIMINADO 01.10.10
	T803007000	CABLEADO RESISTENCI. COE101	RESISTOR WIRING COE101	-	1	-	-	-	-	INTRODUCIDO 01.10.10
	T923006000	CABLEADO RESISTENCI. VPE-061	RESISTOR WIRING VPE-061	-	-	1	-	1	-	ELIMINADO 01.10.10
	T823005000	CABLEADO RESISTENCI. VPE-101	RESISTOR WIRING VPE-101	-	-	-	1	-	1	ELIMINADO 01.10.10
	T823017000	CABLEADO RESISTENCI. VPE-101	RESISTOR WIRING VPE-101	-	-	-	1	-	1	INTRODUCIDO 01.10.10
	T903003000	INSTALACION ELECT COE 061	ELEC. INSTALL. COE 061	1	1	-	-	-	-	ELIMINADO 01.10.10
	T903015000	INSTALACION ELECT COE 061	ELEC. INSTALL. COE 061	1	-	-	-	-	-	INTRODUCIDO 01.10.10
	T803005000	INSTALACION ELECT COE 101	ELEC. INSTALL. COE 101	-	1	-	-	-	-	INTRODUCIDO 01.10.10
	T923004000	INSTAL. ELEC: VISUAL PLUS 061	ELEC. INSTALL. VPE-061	-	-	1	-	1	-	ELIMINADO 01.10.10
	T923017000	INSTALACION ELECT. VPE-061	ELEC. INSTALL. VPE-061	-	-	1	-	1	-	INTRODUCIDO 01.10.10
	T823003000	INSTALACION ELEC.VISUAL PE 10	ELEC. INSTALL. VISUAL PE 10	-	-	-	1	-	1	ELIMINADO 01.10.10
	T823015000	INSTALACION ELEC.VPE 10 11	ELEC. INSTALL. VPE 10 11	-	-	-	1	-	1	INTRODUCIDO 01.10.10
	T843005000	CABLEADO MOTOR XX1	MOTOR WIRING XX1	1	1	1	1	1	1	INTRODUCIDO 01.10.10
	T843005000	CABLEADO MOTOR XX1	MOTOR WIRING XX1	1	1	1	1	1	1	ELIMINADO 28,06,11
	T923010000	CABLEADO MBA 6/11, 10/11	WIRING 6/11, 10/11	-	-	-	-	1	1	ELIMINADO 01.10.10
	T823011000	CABLEADO ADAPT. TFT VPE-061	ADAPT. WIRING TFT VPE-061	-	-	-	-	1	1	ELIMINADO 01.10.10
	T553006000	CABLEADO FUENTE DE ALIMENT.	POWER SUPPLY WIRING	-	-	-	-	1	1	ELIMINADO 01.10.10
	T723008000	CABLE USB VISUAL PLUS	VISUAL PLUS USB CABLE	-	-	-	-	1	1	
	T923010000	CABLEADO MBA 6/11, 10/11	WIRING 6/11, 10/11	-	-	-	-	1	1	
	T843006000	CABLEADO LAVADO 061-101	WIRED WASH 061-101	-	-	-	-	1	1	INTRODUCIDO 01.10.10
	T333009000	CABLEADO LAVADO HEP	WIRED WASH HEP	-	-	-	-	1	1	INTRODUCIDO 01.10.10
	T853003000	CABLEADO TRANSFORMA. - TFT	TRANSFORMER WIRING - TFT	-	-	-	-	1	1	INTRODUCIDO 01.10.10
	T523004000	CABLEADO PULSADOR RESET	RESET BUTTON WIRING	-	-	-	-	1	1	INTRODUCIDO 01.10.10
	T303042000	LEYENDA HORNOS	LEGEND OVENS	1	1	1	1	1	1	HC-76970

COE 061

3N-50/60Hz 380/415V

3-50/60Hz 220V

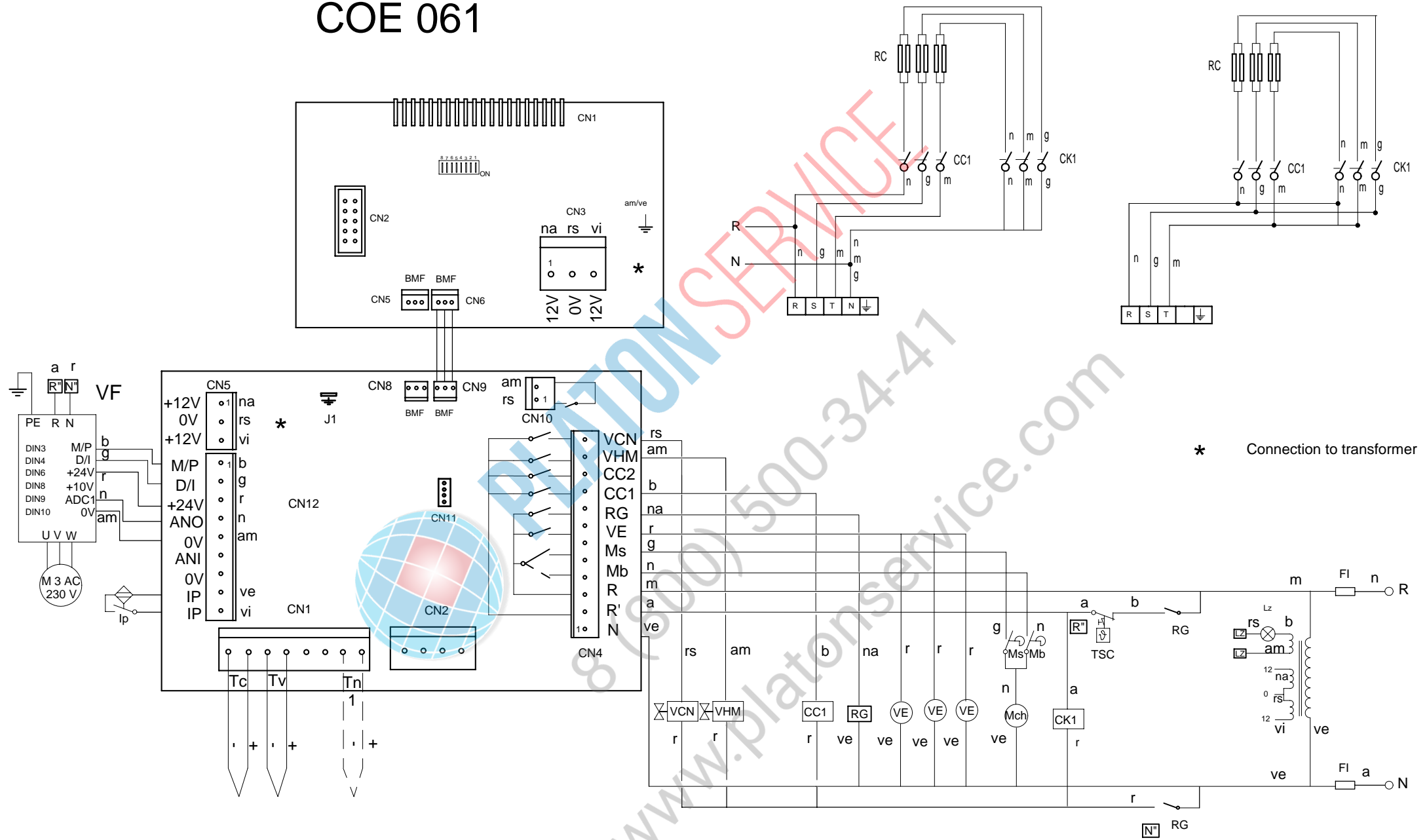

T903001000

VE 061

3N-50/60Hz 380/415V

3-50/60Hz 220V

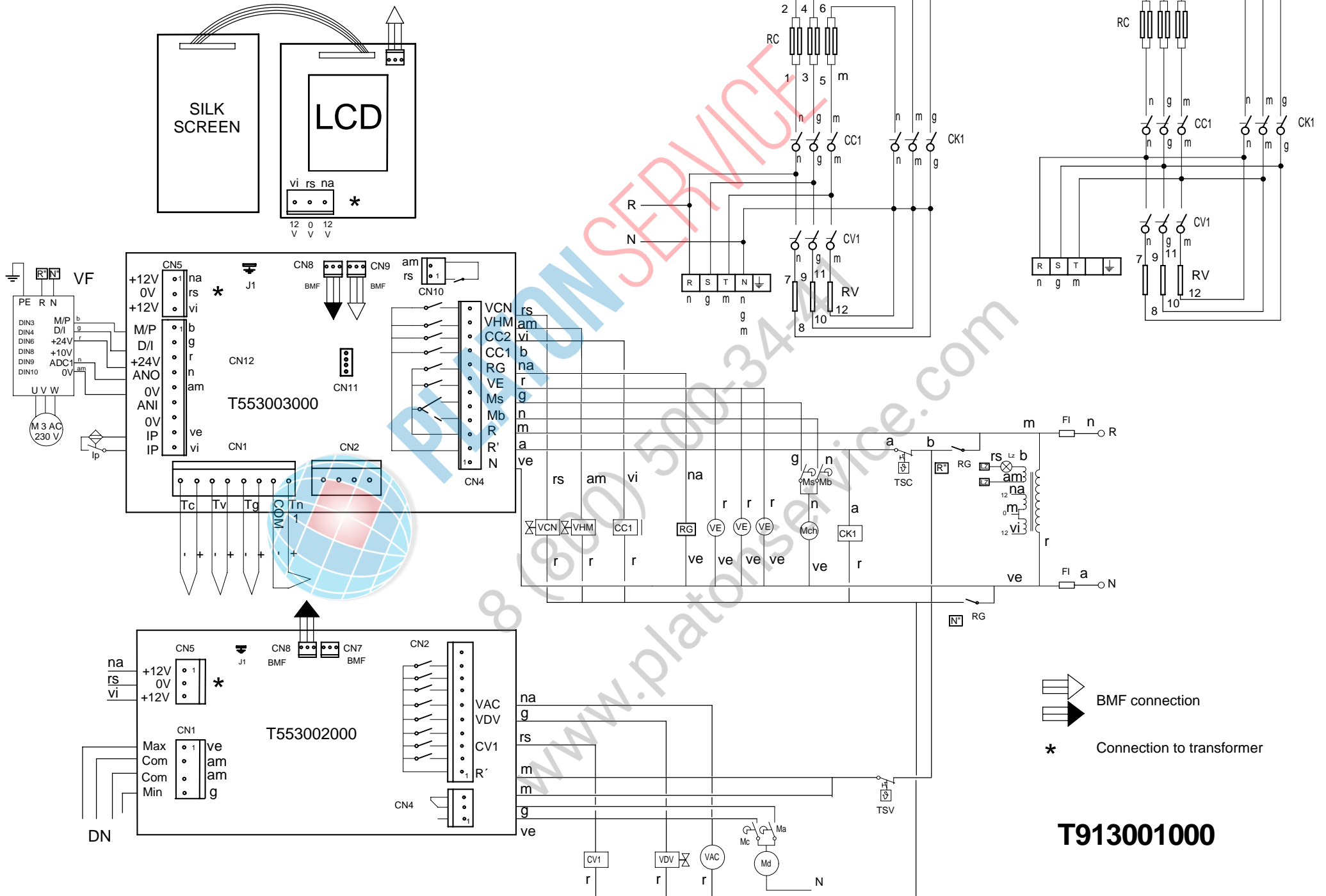

COE 101

3N-50/60Hz 380/415V

3-50/60Hz 220V

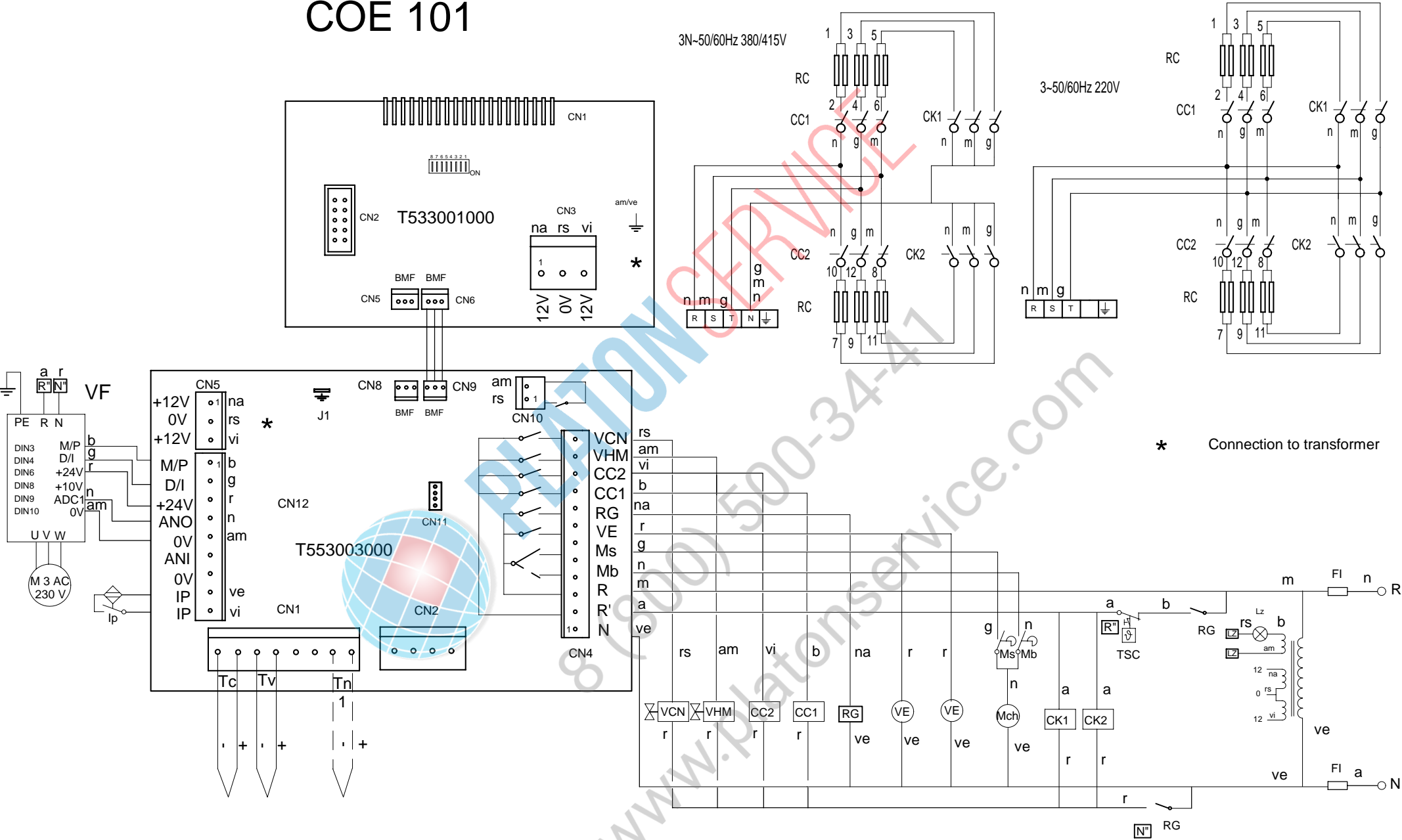

* Connection to transformer

T803003000

VE 101

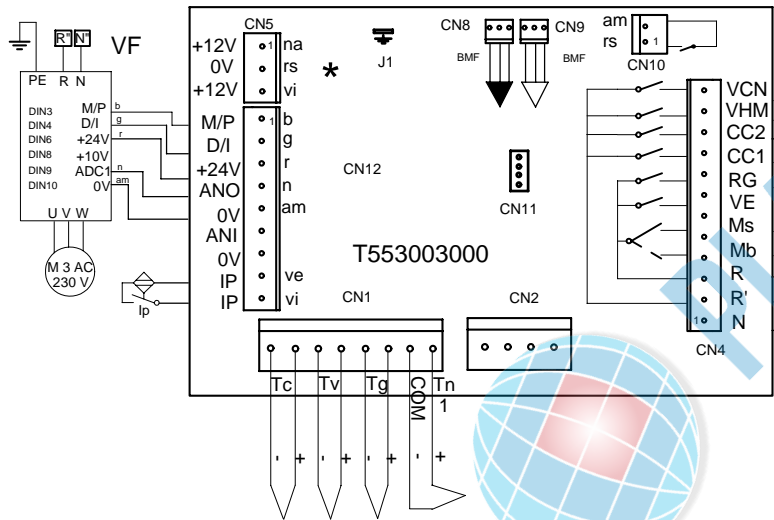
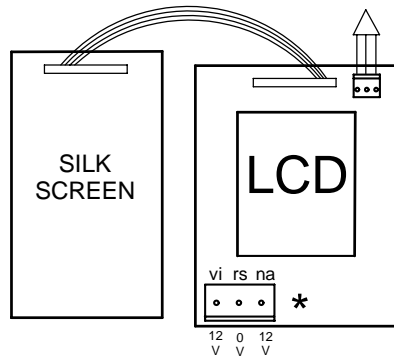

3N-50/60Hz 380/415V

3-50/60Hz 220V

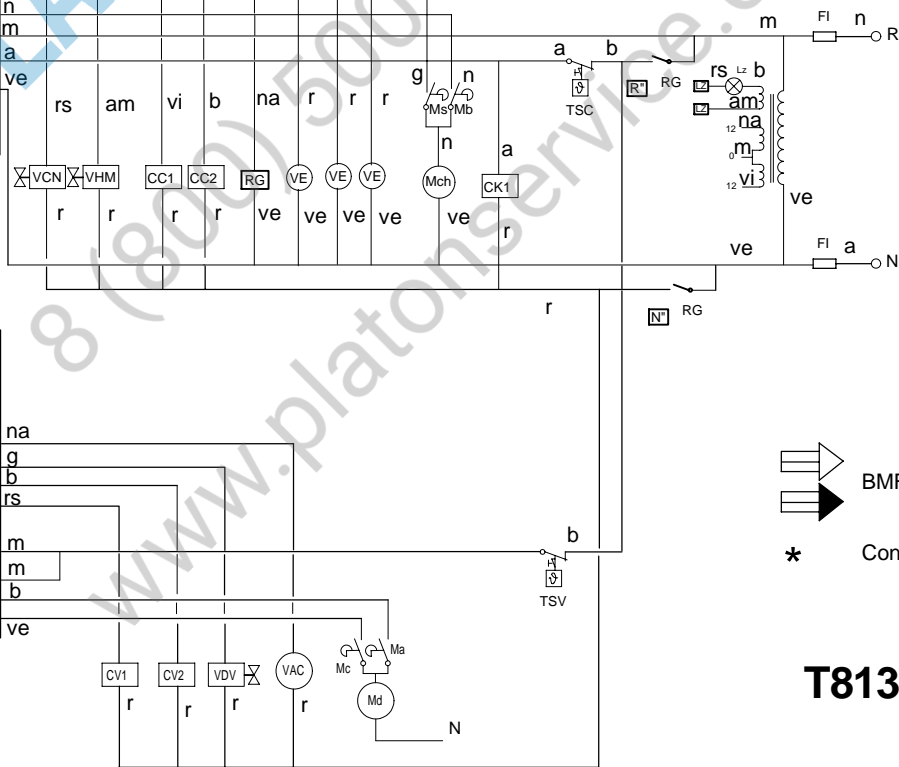
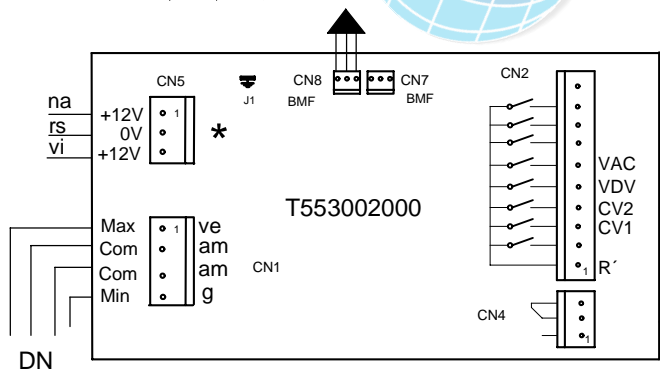
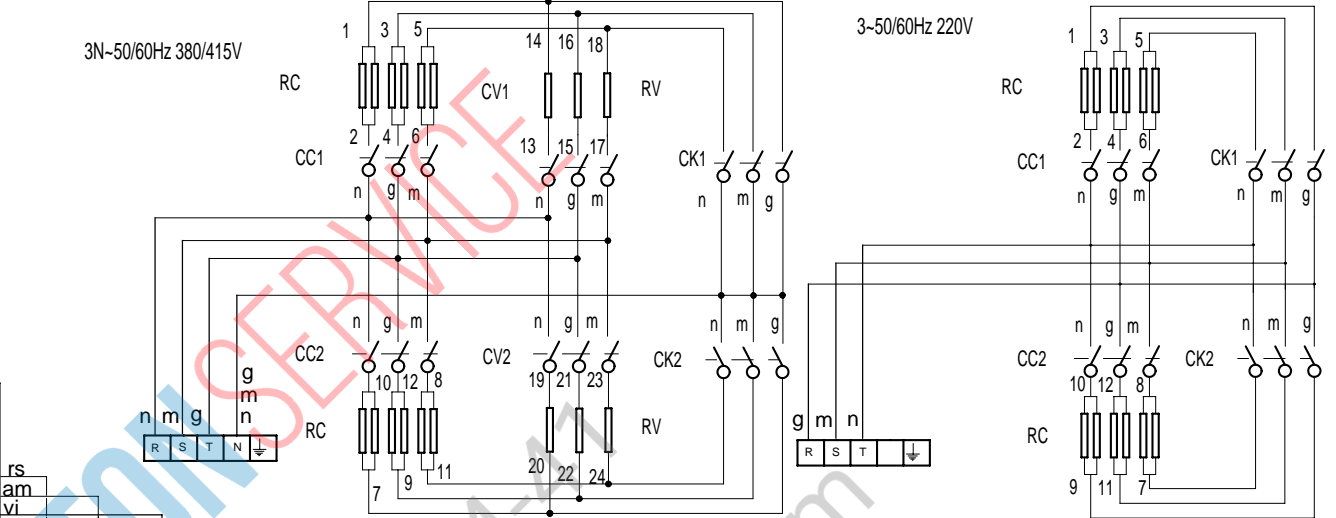

BMF connection
 Connection to transformer

T813003000

VPE 101

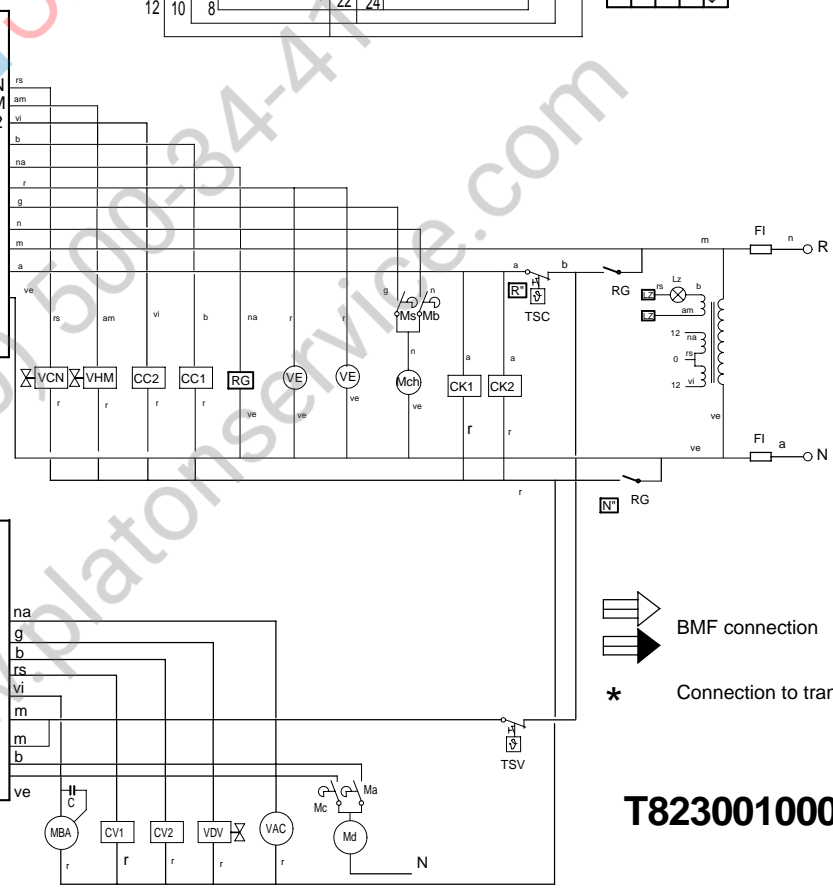
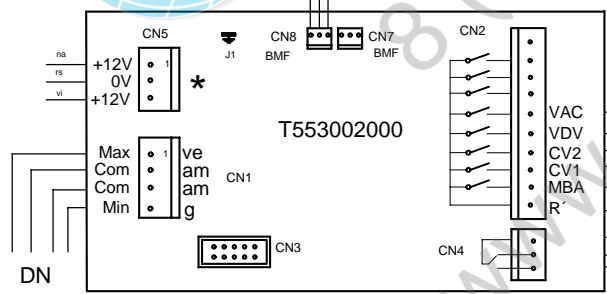
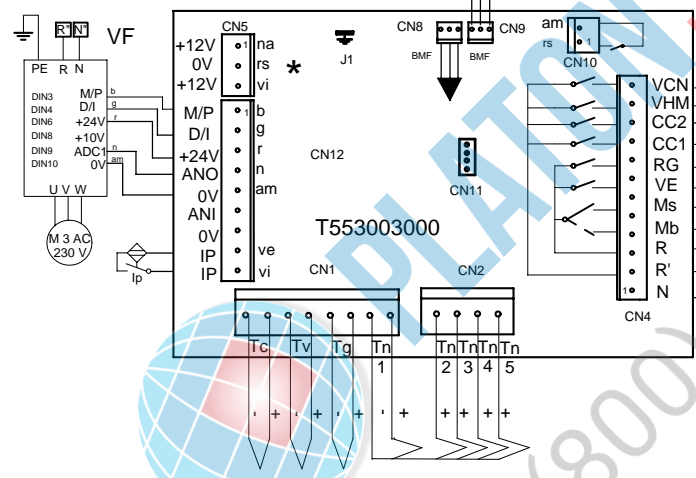
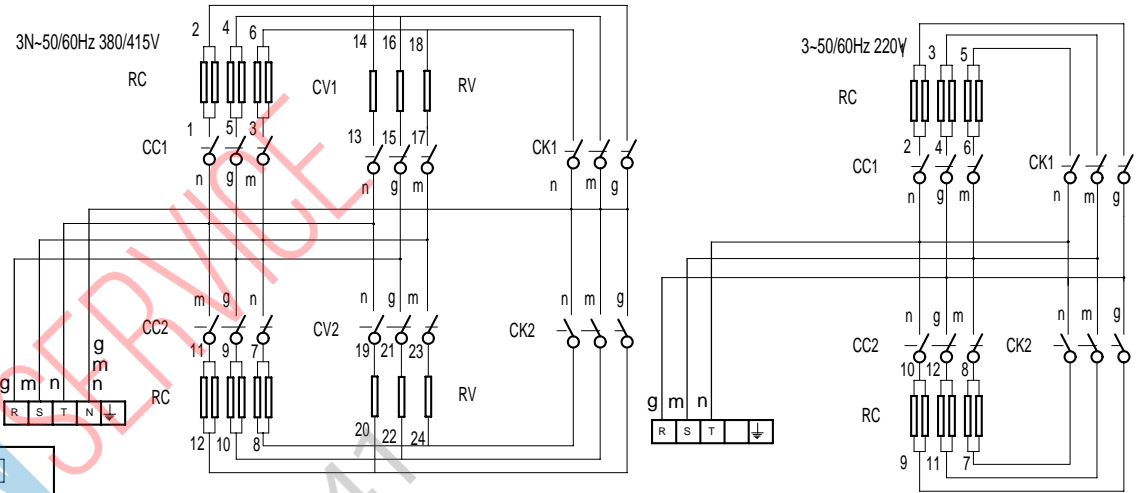
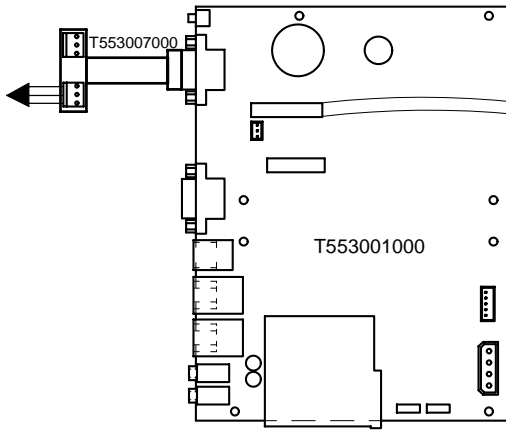

- BMF connection
- Connection to transformer

T823001000

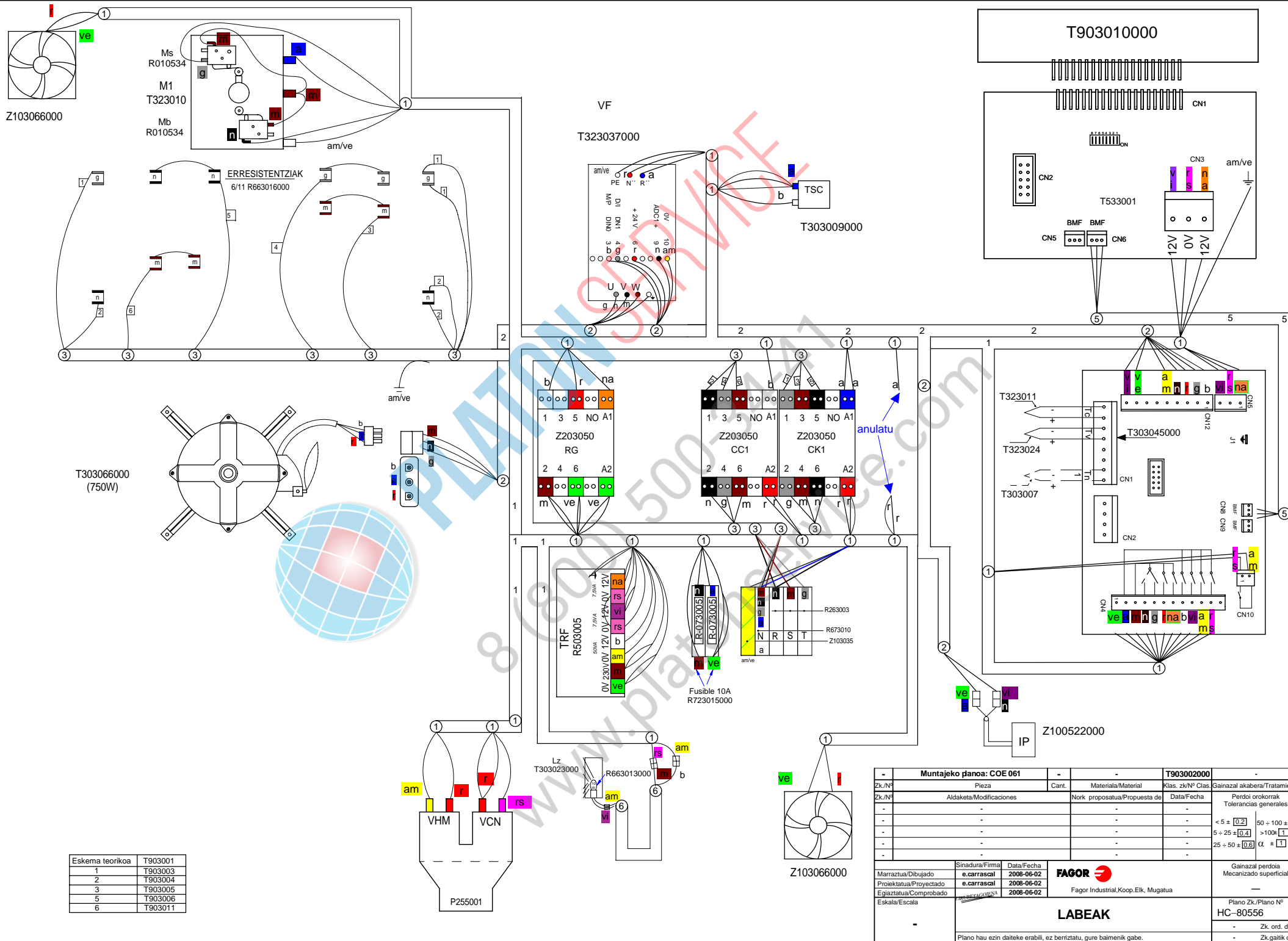

Eskema teorikoa	T903001
1	T903003
2	T903004
3	T903005
5	T903006
6	T903011

Muntajeko plano: COE 061				T903002000		
Zk./Nº	Pieza	Cant.	Materiala/Material	Klas. zk/Nº Clas	Gainazal akabera/Tratamiento	
Zk./Nº	Aldaketa/Modificaciones		Nork proposatua/Propuesta de	Data/Fecha	Perdoi orokorrak Tolerancias generales	
-	-	-	-	-	< 5 ± 0.2	
-	-	-	-	-	50 ± 100 ± 0.8	
-	-	-	-	-	5 + 25 ± 0.2	
-	-	-	-	-	> 100 ± 1	
-	-	-	-	-	25 + 50 ± 0.8	
-	-	-	-	-	α ± 1	
Marratzua/Dibujado	Sinadura/Firma	Data/Fecha	FAGOR Fagor Industrial.Koop.Elk. Mugatua		Gainazal perloia Mecanizado superficial	
Proiektatua/Proyectado	e.carrascal	2008-06-02			LABEAK	Plano Zk./Plano Nº
Egiaztatua/Comprobado	e.carrascal	2008-06-02				HC-80556
Eskala/Escala					-	Zk. ord. du
Plano hau ezin dateke erabili, ez berritzatu, gure baitanik gabe.						

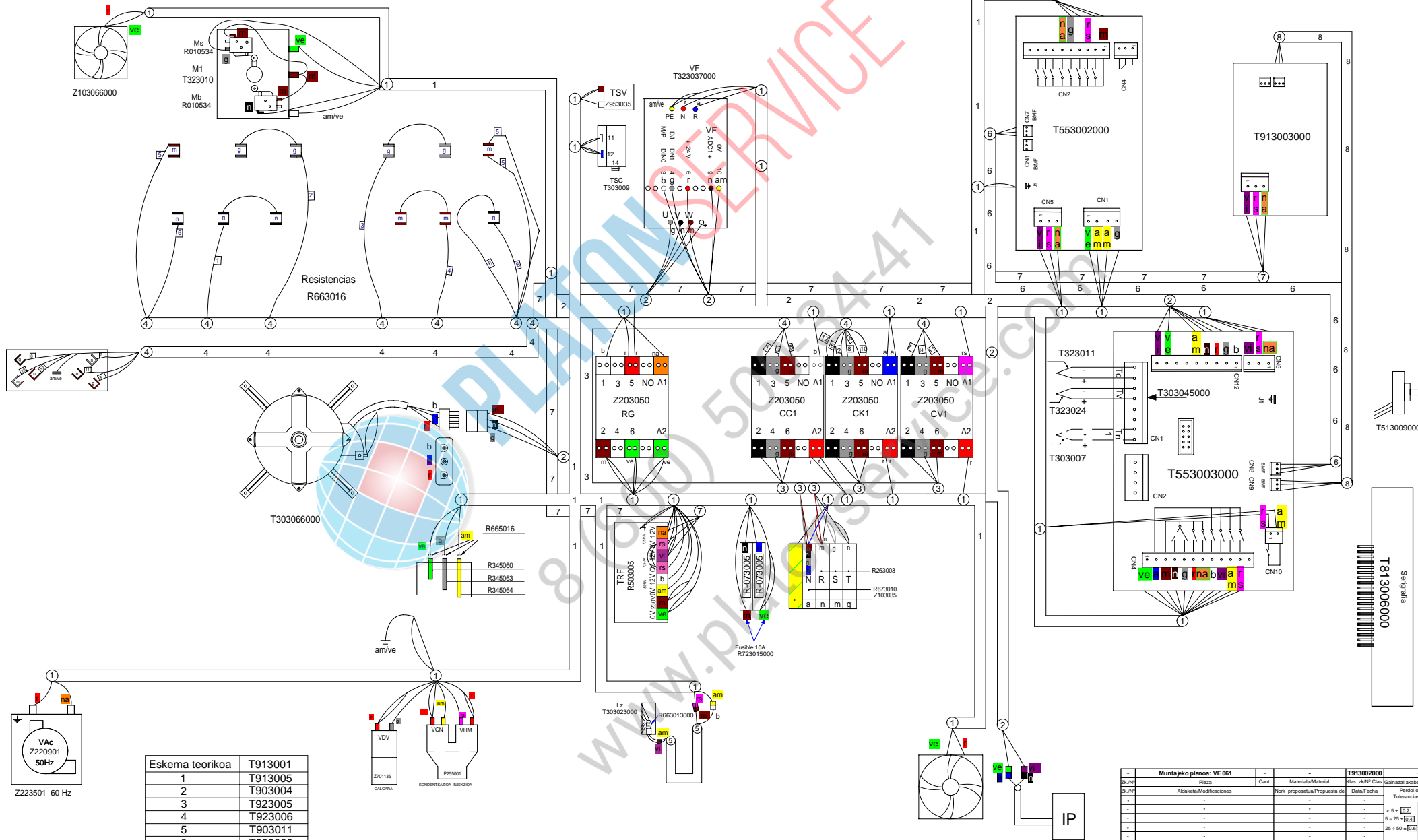

Eskema teorikoa	T913001
1	T913005
2	T903004
3	T923005
4	T923006
5	T903011
6	T903006
7	T913006
8	T903006

Muntatze planoak: VE 061				T913002000	
Zk./Nº	Pieza	Cant.	Materia/Material	Klas. zk/Nº	Clas.
Zk./Nº	Aldaketak/Modificaciones		Nºrik proposatua/Propuesta de		Data/Fecha
					Pertxo erorkorak/Tolerantziak generatzenak
					= 5 x [02] 10 x 100 x [03]
					5 x 25 x [03] x 100 x [03]
					25 x 50 x [03] x [03]
Materia/Oligado			Sinadura/Firma		Data/Fecha
Proiektatzaile/Proyector			E. Carrasco		2008-07-04
Egiazatzaile/Comprobado			E. Carrasco		2008-07-04
Eskola/Escala					
Ganazaila/autor:				Ganazaila/autor:	
FAOR				Mecanizado superficial	
Fagor Industrial, Koop. Elk., Mugatuak					
Eskala/Escala				Plano hau ezin daterik erabili, ez berrintzatu, gure baimenik gabe.	
LABEAK				Plano Zk./Pieza/Nº	
				HC-80786	
				Zk. ord. du.	
				Zk. gaitik ord.	

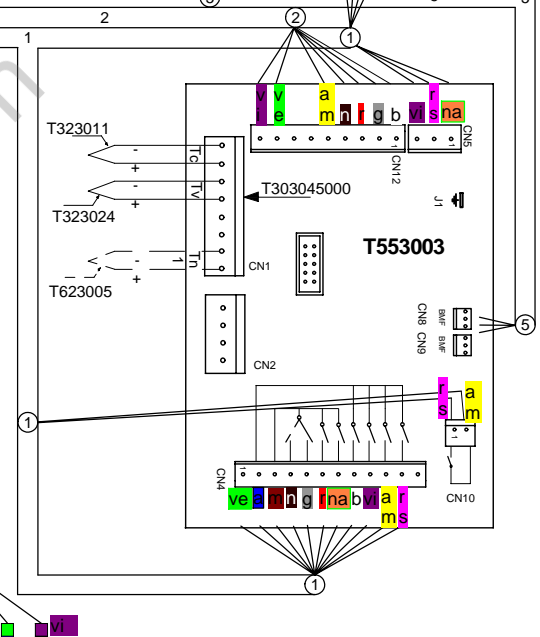
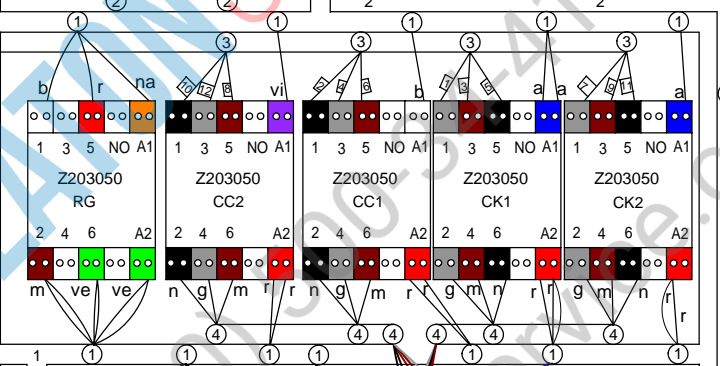
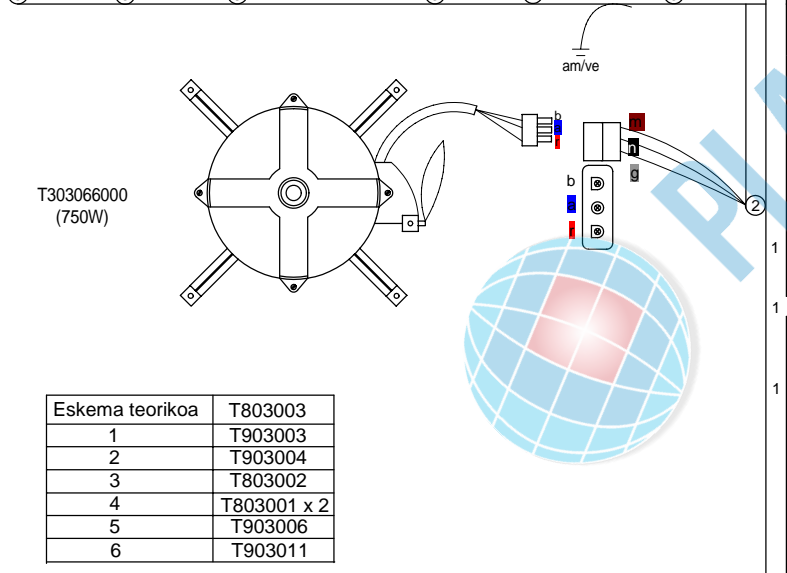
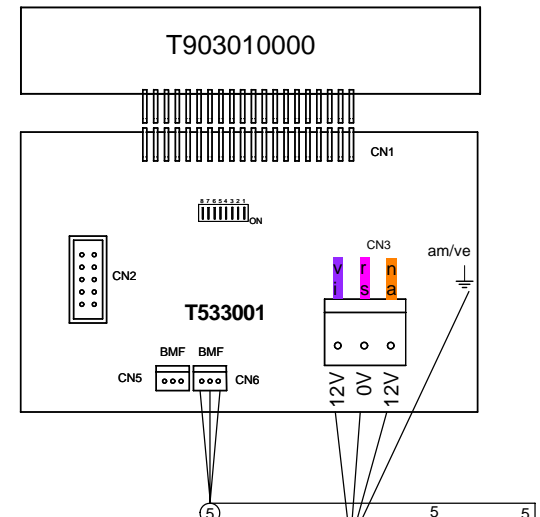
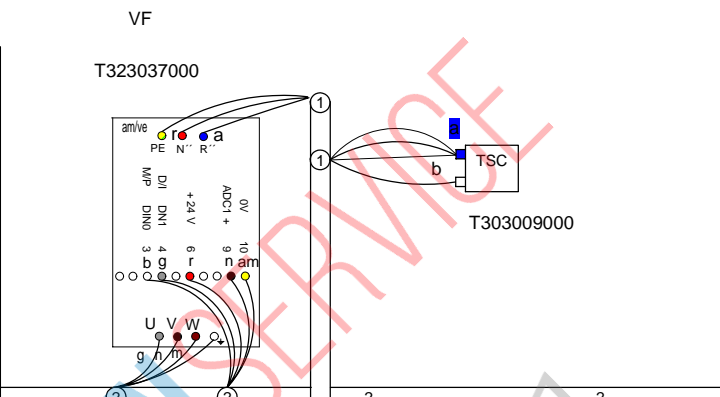
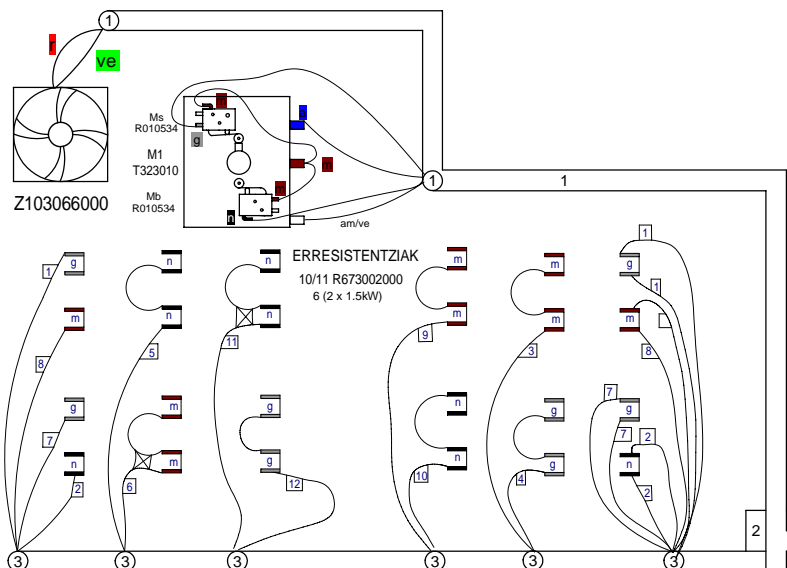

Eskema teorikoa	T803003
1	T903003
2	T903004
3	T803002
4	T803001 x 2
5	T903006
6	T903011

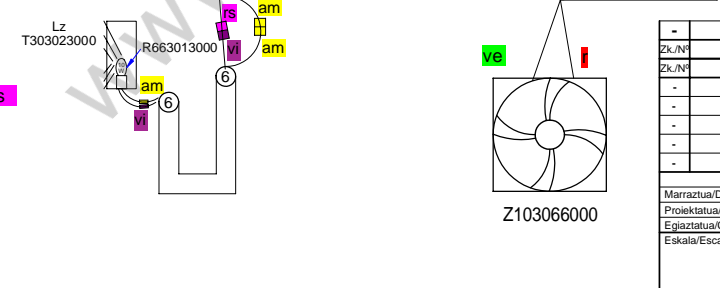
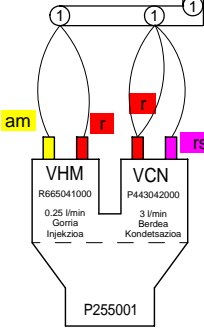
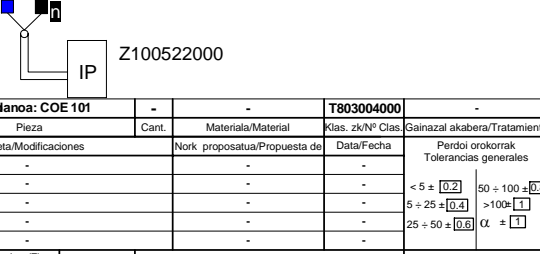
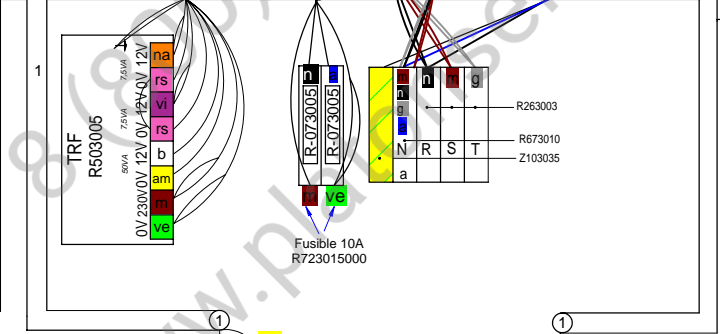

Muntajeko planoak: COE 101			T803004000		
Zk./Nº	Pieza	Cant.	Materiala/Material	Klas. zk/Nº Clas.	Gainazal akabera/Tratamiento
Zk./Nº	Aldaketa/Modificaciones		Nork proposatua/Propuesta de	Data/Fecha	Perdoi orokorrak Tolerancias generales
-	-	-	-	-	< 5 ± 0.2 50 ± 100 ± 0.8
-	-	-	-	-	5 ± 25 ± 0.2 >100 ± 1
-	-	-	-	-	25 ± 50 ± 0.8 α ± 1

Marratzua/Dibujado	Sinadura/Firma	Data/Fecha	 Fagor Industrial.Koop.Elk. Mugatua	Gainazal perloia
Proiektatua/Proyectado	e.carrascal	2008-06-02		Mecanizado superficial
Egiaztatua/Comprobado	e.carrascal	2008-06-02		-
Eskala/Escala	1:1	2008-06-02		-

Plano hau ezin dateke erabili, ez berritzatu, gure baitanik gabe.

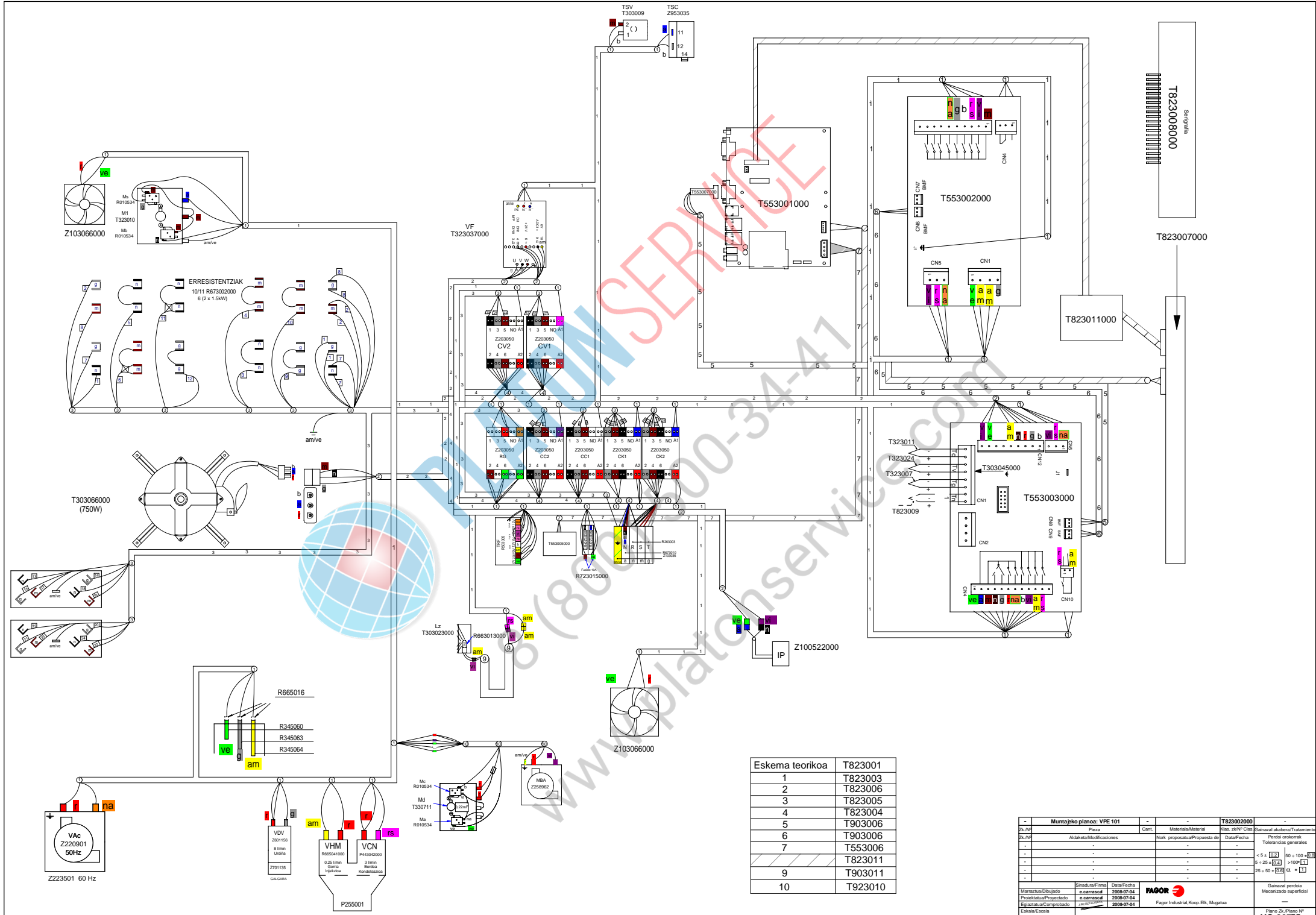

Eskema teorikoa	T823001
1	T823003
2	T823006
3	T823005
4	T823004
5	T903006
6	T903006
7	T553006
	T823011
9	T903011
10	T923010

Muntzako plano: VPE 101				T823002000	
Zk.Nº	Pieza	Cant.	Materia/Material	Klas. zk/Nº	Clas. Ganazail
Zk.Nº	Aldaketak/Modificaciones		Nºrik proposatua/Propuesta de	Data/Fecha	Perdío enkonkretuak/Tolerantziak generatzen
-	-	-	-	-	-
-	-	-	-	-	± 5 x [0,2] 10 x 100 x [0,3]
-	-	-	-	-	15 x 25 x [0,2] 1-100 x [0,3]
-	-	-	-	-	25 x 50 x [0,3] 1 x 1 [0,3]
Murrizketa/Oribatutako: Sinadura/Firma: Data/Fecha: FAOOR Proiektatzaile/Proyector: e.carrascal 2008-07-04 Egiaztatua/Comprobado: e.carrascal 2008-07-04 Eskala/Escala:				Ganazaila/abakera/Treatmento: Mecanizado superficial Ganazaila/abakera/Treatmento: Mecanizado superficial	
Eskema/Escala: LABEAK				Planoa/Plano: HC-80755 Zk. ord. du: - Zk. gaitik ord: -	

Plano hau ezin daterik enabli, ez berritatu, gure baimenik gabe.

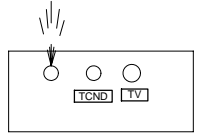
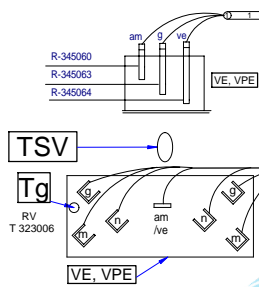
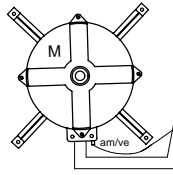
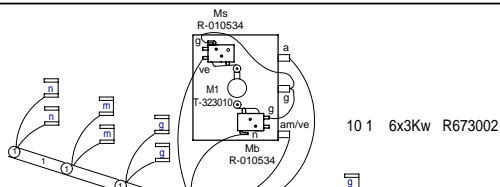

VPE

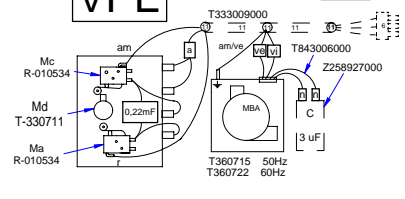

10.1 6x3Kw R673002

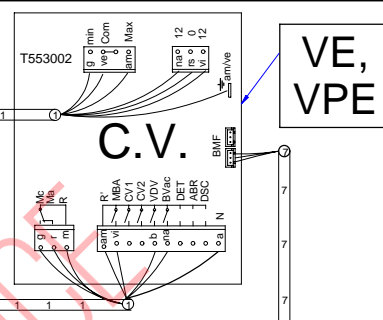
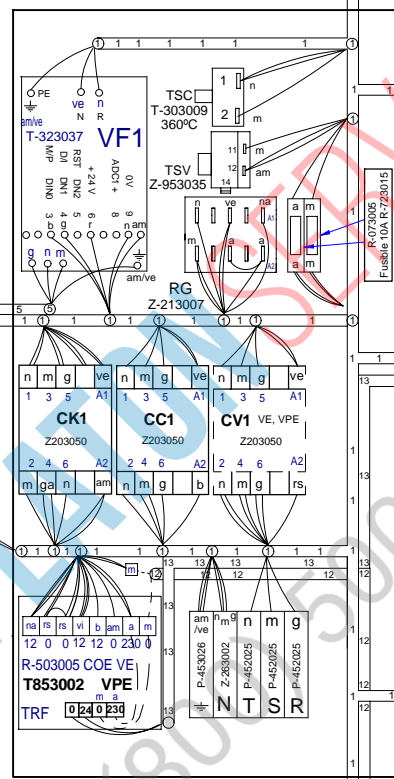

VE, VPE

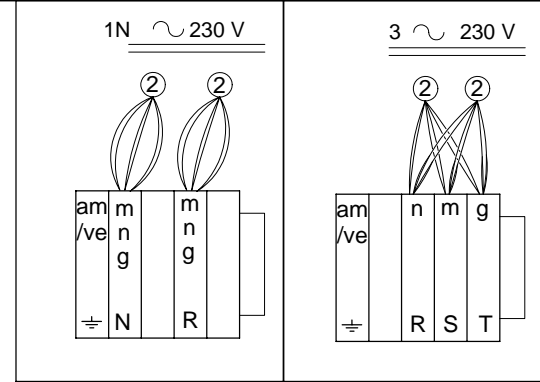

	COE 06 1	VE, VPE, 06 1
Genrl	1	T823015 T923017
Prolong	5	T843005
BMF	7	T923016
Lav (VPE)	11	T333009
Rst (VPE)	12	T523004
TFT (VPE)	13	T853003
USB (VPE)	14	T723008
Esquema	-	T643005000
Leyenda	-	T303042000
Ind.Comp	-	T303043000

COPIAR PARAMETROS DESDE EL BOP AL VARIADOR

P0003 = 3
P0010 = 30
P0803 = 1

SOLO USAR CUANDO EL BOP SE HA BORRADO

P0802 desde Variador a BOP

Variador de Siemens.
Pulsar [F] para entrar o salir de los Parmtros.
Nota. Si se modifica algun valor del nivel Basico, hay que volver a grabar el nivel 3.

P0010 = 1 Para inicio programación. (Nivel Basico)
P0100 = 0 (Valor en KW 50Hz Europa)
P0304 = 230 (Vn V)
P0305 = 1.8 (Inb A)
P0307 = 0.37 (Pn kW)
P0310 = 50 (Fn Hz)
P0311 = 1400 (rpm Nom)
P0700 = 2 (Terminal)
P1000 = 2 (Consigna ADC)
P1080 = 25 (F.min Hz)
P1082 = 50 (F.Max Hz)
P1120 = 5° (Ton °)
P1121 = 5° (Toff °)
P3900 = 1 (Fin de la programación y grabación de datos.)
P0003 = 3 Nivel 3 Experto.
P0005 = 27 (Visualización = Corriente de salida)
P0611 = 16000 (Tiempo de activación de sobrecarga Seg.)
P0640 = 150 (Sobrecarga de corriente en %)
P1210 = 6 (Rearranque automático)
P1300 = 2 (Modo Parada, Ventilador)
P1800 = 16 (F.Base KHz) (Cuantos mas alto = ruido acústico)
P2000 = 50 (F.Referencia de la consigna Hz)

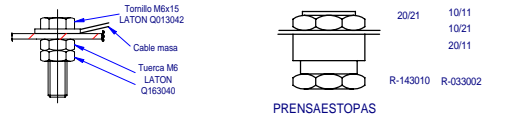

Plano Montaje COE, VE, VPE, 06 1, 06 1		400 V		T923055000	
Zk./Nº	Pieza	Cant.	Material/Material	Klas. zk/Nº Clas	Gainazal akabera/Tratamiento
Zk./Nº	Aldaketa/Modificaciones	Nork proposatua/Propuesta de	Data/Fecha		Perdoi orokorrak Tolerancias generales
-	-	-	-	-	< 5 ± 0.2 50 ± 100 ± 0.8
-	-	-	-	-	5 ± 25 ± 0.4 >100 ± 1
-	-	-	-	-	25 ± 50 ± 0.6 α ± 1

Marratzua/Dibujado: **M.Maillito** 12-05-2010
 Proiektatua/Proyectado: **M.Maillito** 12-05-2010
 Egiaztatua/Comprobado: **M.Maillito** 12-05-2010

Sinadura/Firma: _____ Data/Fecha: _____

FAGOR
Fagor Industrial.Koop.ElK, Mugautua

Gainazal perdoia Mecanizado superficial

HORNOS
HD - 13201

Plano Zk./Plano Nº
- Zk. ord. du
- Zk.gaitik ord.

Plano hau ezin dateke erabili, ez berritatu, gure baituenik gabe.

	ESPAÑOL	FRANÇAIS	ENGLISH	DEUTSCH	ITALIANO
BEC	Bujía Encendido Cámara	Chamber Allumage Chambre	Zündkerze Spark Plug	Zündkerze Einschalten Garraum	Candela di Accensione Camera
BEV	Bujía Encendido Caldera	Bougie Allumage Chaudière	Boiler Spark Plug	Zündkerze Einschalten Boile	Candela di Accensione Caldaia
C.C.	Control Camara	Contrôle Chambre	Chamber Control	Steuerung Garraum	Controllo Camera
C.E.C	Control Combustión Cámara	Contrôle Combustion Chambre	Chamber Combustion Control	Steuerung Verbrennung Garraum	Controllo Combustione Camera
C.E.V	Control Combustión Caldera	Contrôle Combustion Chaudière	Boiler Combustion Control	Steuerung Verbrennung Boiler	Controllo Combustione Caldaia
C.G.	Control Gas	Contrôle Gaz	Control Gas	Steuern Sie Gas	Controlli il gas
C.V.	Control Caldera	Contrôle Chaudière	Boiler Control	Steuerung Boiler	Controllo Caldaia
CC1, CC2	Contactador Resistencia Cámara	Contacteur Élément Chauffant Chambre	Chamber Heating Element Contactador	Schütz Heizwiderstand Garraum	Contattore Resistenza Camera
CK1, CK2	Contactador General Calentamiento	Relais Élément Chauffant	Heating Element Relay	Relais Heizwiderstand	Relè Resistenza
CV1, CV2	Contactador Resistencias Caldera	Contacteur Élément Chauffant Chaudière	Boiler Heating Element Contactador	Schütz Heizwiderstand Boiler	Contattore Resistenza Caldaia
DEC	Detector Llama Cámara	Détecteur Flamme Chambre	Chamber Flame Detector	Flammendetektor Garraum	Rilevatore di Fiamma Camera
DEV	Detector Llama Caldera	Détecteur Flamme Chaudière	Boiler Flame Detector	Flammendetektor Boiler	Rilevatore di Fiamma Caldaia
DN	Detector Nivel Caldera	Détecteur Niveau Chaudière	Boiler Level Detector	Pegeldetektor Boiler	Rilevatore Livello Caldaia
F	Fusibles	Fusibles	Fuses	Sicherungen	Fusibili
FI	Filtro Interferencias	Filtre Interférences	Interference Filter	Störungsfilter	Filtro Interferenze
FM	Térmico Motor	Thermique Moteur	Thermal Engine	Thermoschalter Motor	Termico Motore
GV1, GV2	Electro válvula Gas Cámara	Électrovanne Gaz Chambre	Chamber Gas Solenoid Valve	Elektroventil Gas Garraum	Elettrovalvola Gas Camera
GV3, GV4	Electro válvula Gas Caldera	Électrovanne Gaz Chaudière	Boiler Gas Solenoid Valve	Elektroventil Gas Boiler	Elettrovalvola Gas Caldaia
Ip	Interruptor Seguridad Puerta	Interrupteur Sécurité Porte	Door Safety Switch	Sicherheitsschalter Tür	Itteruttore Sicurezza Porta
Lz	Luz Interior	Éclairage Intérieur	Inner Light	Innenbeleuchtung	Luce Interna
M, M2	Motor Turbina	Moteur Turbine	Turbine Engine	Motor Turbine	Motore Turbina
Ma	Interruptor Micro Abierto	Microrupteur Ouvert	Open Microswitch	Mikroschalter Geöffnet	Itteruttore Micro Aperto
Mb	Interruptor Micro Bajada	Microrupteur Descente	Drop Microswitch	Mikroschalter Senken	Itteruttore Micro Discesa
Mc	Interruptor Micro Cerrado	Microrupteur Fermé	Closed Microswitch	Mikroschalter Geschlossen	Itteruttore Micro Chiuso
Mch	Motor Chimenea	Moteur Cheminée	Stack Engine	Motor Abluftkamin	Motore Canna
MD	Motor Desague	Moteur évacuation	Drain Engine	Motor Abfluss	Motore scolo
Ms	Interruptor Micro Subida	Microrupteur Montée	Rise Microswitch	Mikroschalter Heben	Itteruttore Micro Salita
PF	Potenciómetro Selector Funciones	Potentiomètre Sélecteur Fonctions	Functions Selector Potentiometer	Potentiometer Funktionswahlschalter	Potenziometro Selettore Funzioni
RC	Resistencias Cámara	Éléments Chauffants Chambre	Chamber Heating Element	Heizwiderstände Garraum	Resistenze Camere
RG	Rele General	Relais Général	Main Relay	Hauptrelais	Relè principale
RV	Resistencias Caldera	Éléments Chauffants Chaudière	Boiler Heating Element	Heizwiderstände Boiler	Resistenze Caldaia
Tc	Sonda Cámara	Sonde Chambre	Chamber Probe	Sonde Garraum	Sonda Camera
TCN	Termostato Condensación	Thermostat Condensation	Condensation Thermostat	Thermostat Kondensierung	Termostato Condensazione
Tg	Sonda Caldera	Sonde Chaudière	Boiler Probe	Sonde Boiler	Sonda Caldaia
Tn	Sonda Núcleo	Sonde Noyau	Core Probe	Kerntemperaturmesssonde	Sonda Nucleo
TRF	Transformador	Transformateur	Transformer	Transformator	Trasformatore
TSC	Termostato Seguridad Cámara	Thermostat Sécurité Chambre	Chamber Safety Thermostat	Sicherheitsthermostat Garraum	Termostato Sicurezza Camera
TSV	Termostato Seguridad Caldera	Thermostat Sécurité Chaudière	Boiler Safety Thermostat	Sicherheitsthermostat Boiler	Termostato Sicurezza Caldaia
Tv	Sonda Vapor	Sonde Vapeur	Steam Probe	Sonde Dampf	Sonda Vapore
VAC	Bomba Vaciado	Pompe Vidange	Vacuum Pump	Ablasspumpe	Pompa scarico
MBA	Moto Bomba Aclarado	Pompe Rinçage	Rinsing Pump	Pumpe Ausspülen	Pompa Risciacquo
VC1, VC2	Ventilador Soplane Camara	Ventilateur Soufflant	Blowing Fan	Ventilator Gebläse	Ventilatore Soffiante
VCN	Electro válvula Condensación	Électrovanne Condensation	Condensation Solenoid Valve	Elektroventil Kondensierung	Elettrovalvola Condensazione
VDV	Electro válvula Llenado Caldera	Électrovanne Remplissage Chaudière	Chamber Filling Solenoid Valve	Elektroventil Füllung Boiler	Elettrovalvola di Riempiemento Caldaia
VE	Ventilador Cuadro Eléctrico	Ventilateur Tableau Électrique	Fan Switchboard	Ventilator Elektrotafel	Ventilatore Quadro Elettrico
VF1, VF2	Variador de Frecuencia	Variateur Vitesse	Speed Variator	Geschwindigkeitsregler	Variatore di Velocità
VHM	Electro válvula Humidificador	Électrovanne Humidificateur	Humidifier Solenoid Valve	Elektroventil Befeuchtungsrichtung	Elettrovalvola Umidificatore
Vv	Ventilador Soplane Caldera	Ventilateur soufflement chaudière	Boiler Blowing Fan	Durchbrennenventilator zum Dampfkessel	Ventilatore Soffiante caldaia
	COLORES	COULEURS	COLOUR	FARBEN	COLORE
a	Azul	Bleu	Blue	Blau	Blu
am	Amarillo	Jaune	Yellow	Gelb	Giallo
am/ve	Amarillo/verde	Jaune / vert	Yellow / green	Gelb/grün	Giallo/verde
b	Blanco	Blanc	White	Weiß	Bianco
g	Gris	Gris	Grey	Grau	Grigio
m	Marrón	Marron	Brown	Braun	Marrone
n	Negro	Noir	Black	Schwarz	Nero
na	Naranja	Orange	Orange	Orange	Arancio
r	Rojo	Rouge	Red	Rot	Rosso
rs	Rosa	Rose	Pink	Rosa	Roseo
ve	Verde	Vert	Green	Grün	Verde
vi	Violeta	Violet	Purple	Violett	Viola